

Terminal velocity

Screw or spring connection

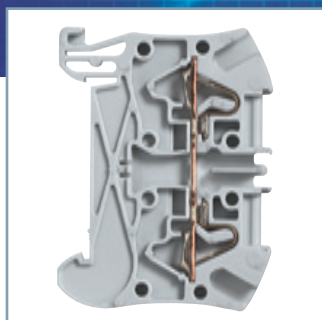
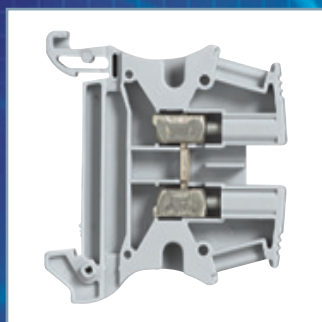

NEW VIKING 3 TERMINALS / PRODUCT GUIDE

■ POWERED BY SPECIALISTS

 **legrand**[®]

www.legrand.co.uk

Global vision...

21st Century solutions

Why choose Legrand?

In a word, confidence. Legrand is a world leader in its field, with offices and subsidiaries in more than 60 countries and sales in around 180 countries. Globally, Legrand holds 19% of the wiring devices market and 15% of the cable management market.

Innovation for progress

Legrand invests heavily in research and development. It has nearly 1,800 people around the world inventing, designing, testing and validating new ideas.

By actively focusing on new product development, Legrand is able to launch new ranges that facilitate installation for the contractor and simplify usage for the end user.



Sustainable development

Legrand relies heavily on its core values and on the expertise of its teams to ensure profitable, long-lasting and responsible growth... combining long-term performance with environmental conservation and the valuing of human resources.

Products and systems for electrical installations and information networks

Screw or spring connection

Legrand has been manufacturing Viking 3 terminals in its Normandy factories for over 30 years. Millions of installers throughout the world use the range and have watched it evolve into an industry benchmark.

Used together with Legrand's CAB 3 marking system and Starfix ferrules, Viking 3 completes the package of solutions for reliable, easy to use connection systems.

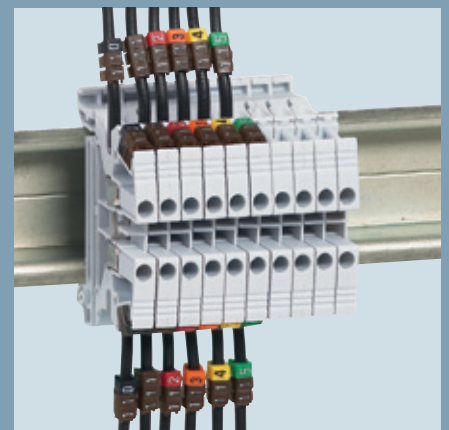

Viking 3 terminal blocks with CAB 3 marking system



Contents

Overview

Screw connection	2
Spring connection	4
Common accessories	6

Catalogue and technical information

Selection charts	8
Screw connection terminal blocks	14
Spring connection terminal blocks	16
Accessories for screw and spring connection	18
Heavy duty terminal blocks	24
Marking systems	27
Starfix ferrules and crimping tools	30

Strength and security

Screw connection

High contact pressure using the clamp/bar system

Captive screw

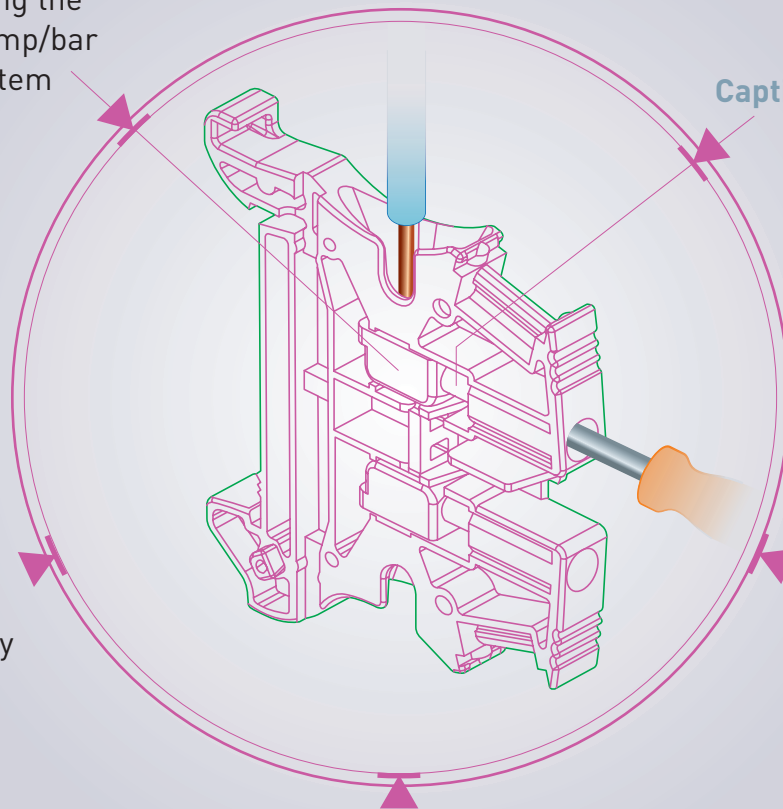

Excellent mechanical strength with a high quality surface-treated steel clamp⁽¹⁾

Tried and tested for strength, retention, destructive torque-resistance and ageing

Perfect electrical conduction with the tinned brass bar⁽¹⁾

PERMISSIBLE CROSS-SECTIONS:

0.25 mm² to 70 mm² (flexible cable) and 0.25 mm² to 95 mm² (rigid cable)

(1) Complies with RoHS (Restriction of Hazardous Substances) requirements

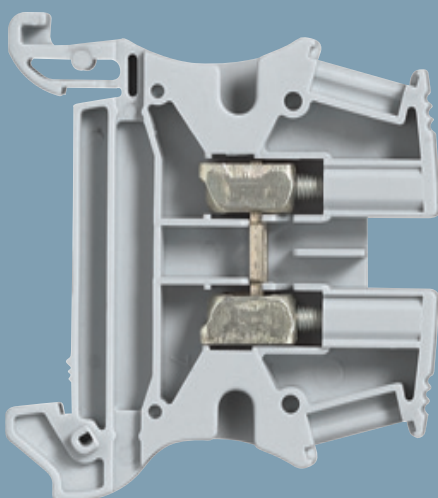

International approvals:
UL/CSA/NF/VDE/IMQ/BV
ATEX certification



Conforms to IEC EN 60947-7-1,
IEC EN 60947-7-2 and IEC EN 60947-7-3

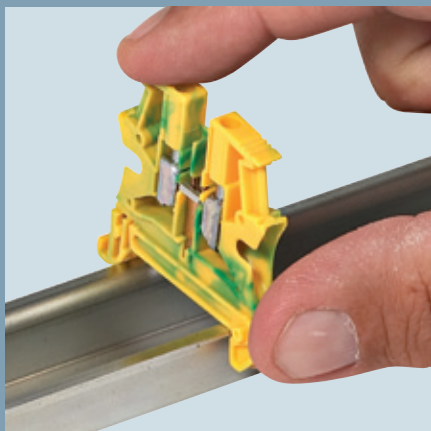

Direct screwless fixing on rail for protection conductor modules up to 10 mm width

Simple innovation

Optimised size, simplified fixing and standardised end caps on the new Viking 3 range make installation, connection and marking easier than ever.



Identical height for blocks of 16 to 70 mm

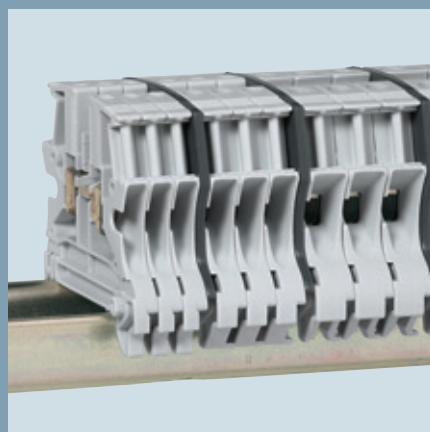

Single end caps for widths of 5 to 10 mm

Reliability and time saving

Spring connection

No connection tool required

Direct insertion⁽¹⁾ up to 6 mm width.
Disconnection with screwdriver

Constant contact pressure

Easy management of cables

with inclined cable entries

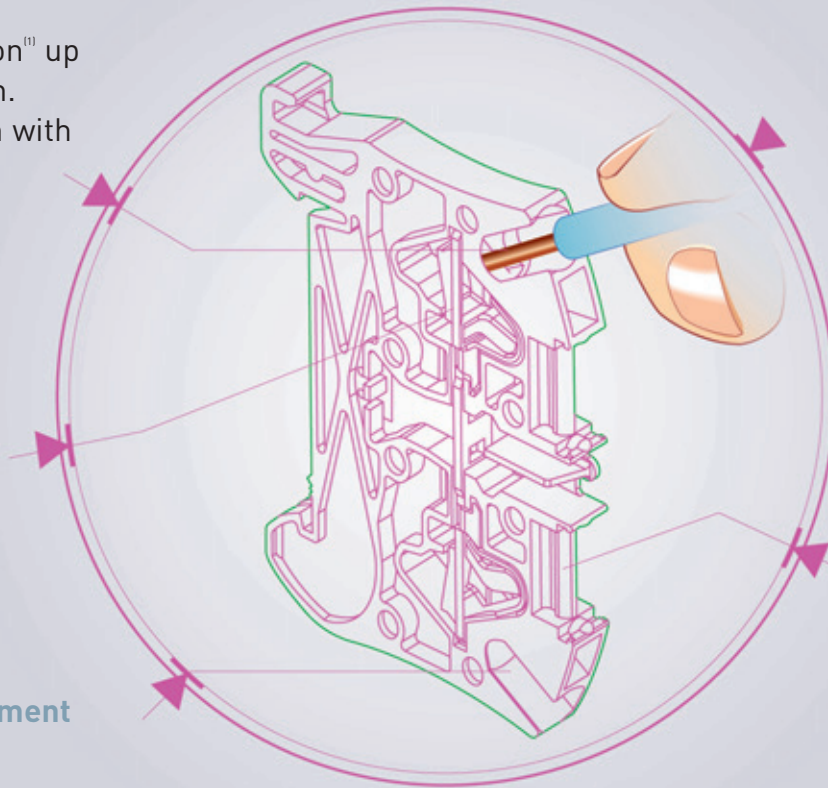

Automatic connection

With or without ferrules

Double central marking area

PERMISSIBLE CROSS-SECTIONS:

0.5 mm² to 16 mm²

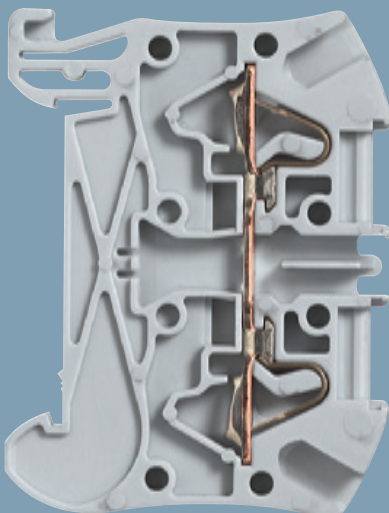

International approvals:
UL/CSA/NF/VDE/IMQ/BV
ATEX certification



Conforms to IEC EN 60947-7-1,
IEC EN 60947-7-2 and IEC EN 60947-7-3



Integrated end caps for widths of 6 to 12 mm

Springing into action

In response to installer feedback, Legrand's Research and Development team has created an innovative range of spring terminal blocks that offers many new advantages... all with high connection quality.

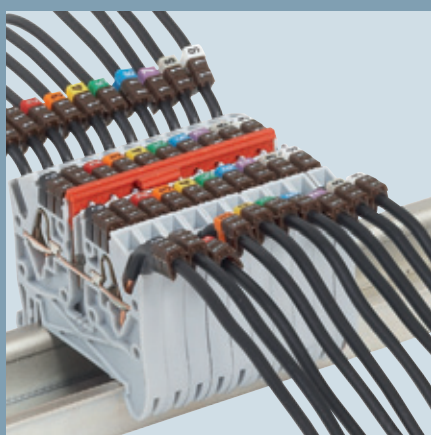

Bridging combs and markings are perfectly visible

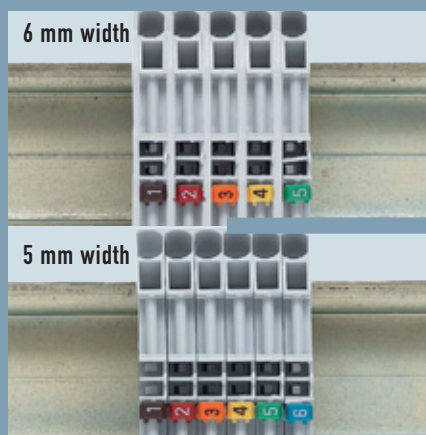

Compact terminal blocks mean that valuable space can be saved

Common accessories

For screw and spring terminals

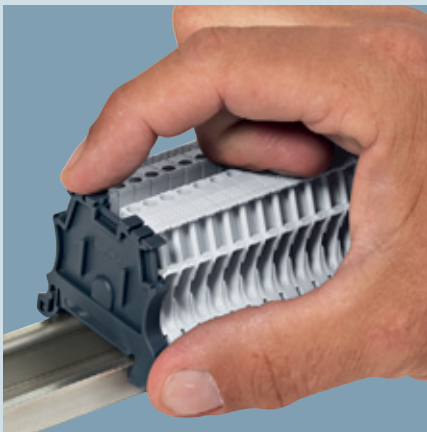
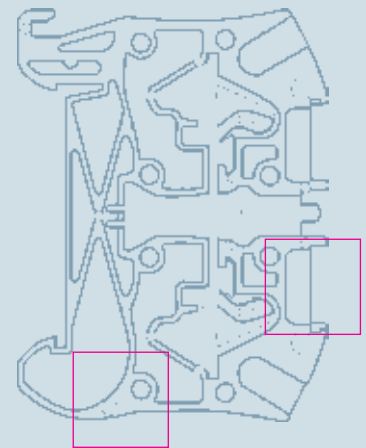
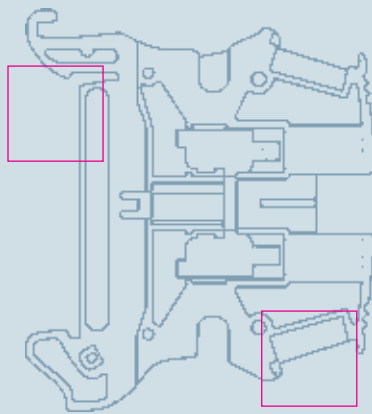

End stop with screwless fixing

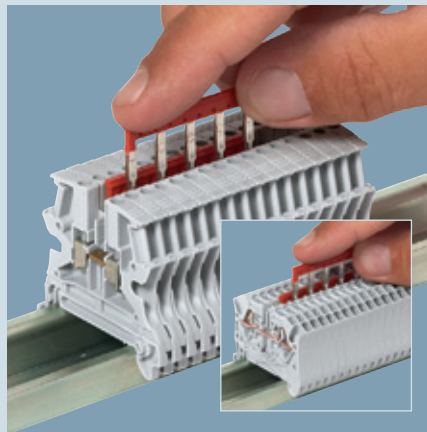

Bridging comb with automatic insertion
up to 8 mm (screw) or 12 mm (spring) widths

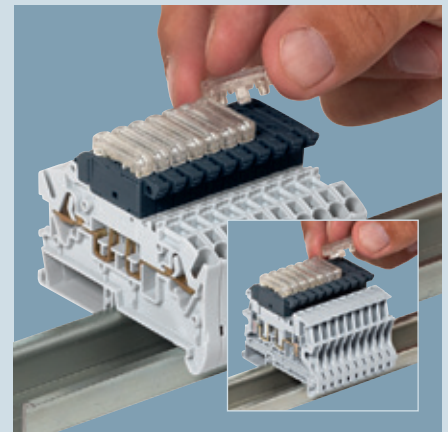

Indication of blown fuses
(12 / 48 V or 110 / 250 V)

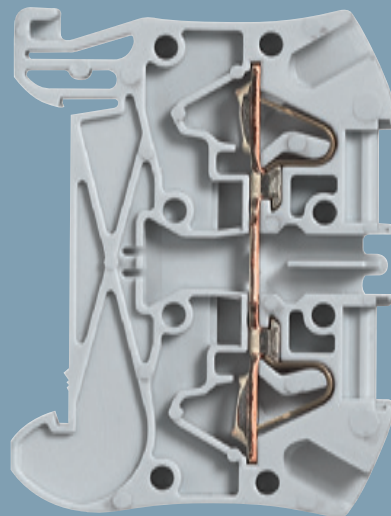
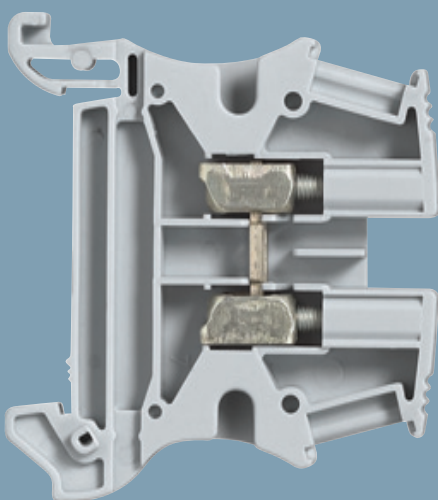

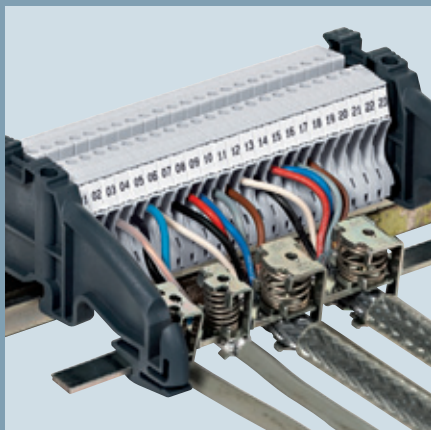

Cable shielding with dedicated accessories



Additional functions can be added: standard, neutral or protected isolation, MCBs, automotive-type fuses, etc...



CAB 3 integrated marking system

More convenient wiring and easier installation with common accessories

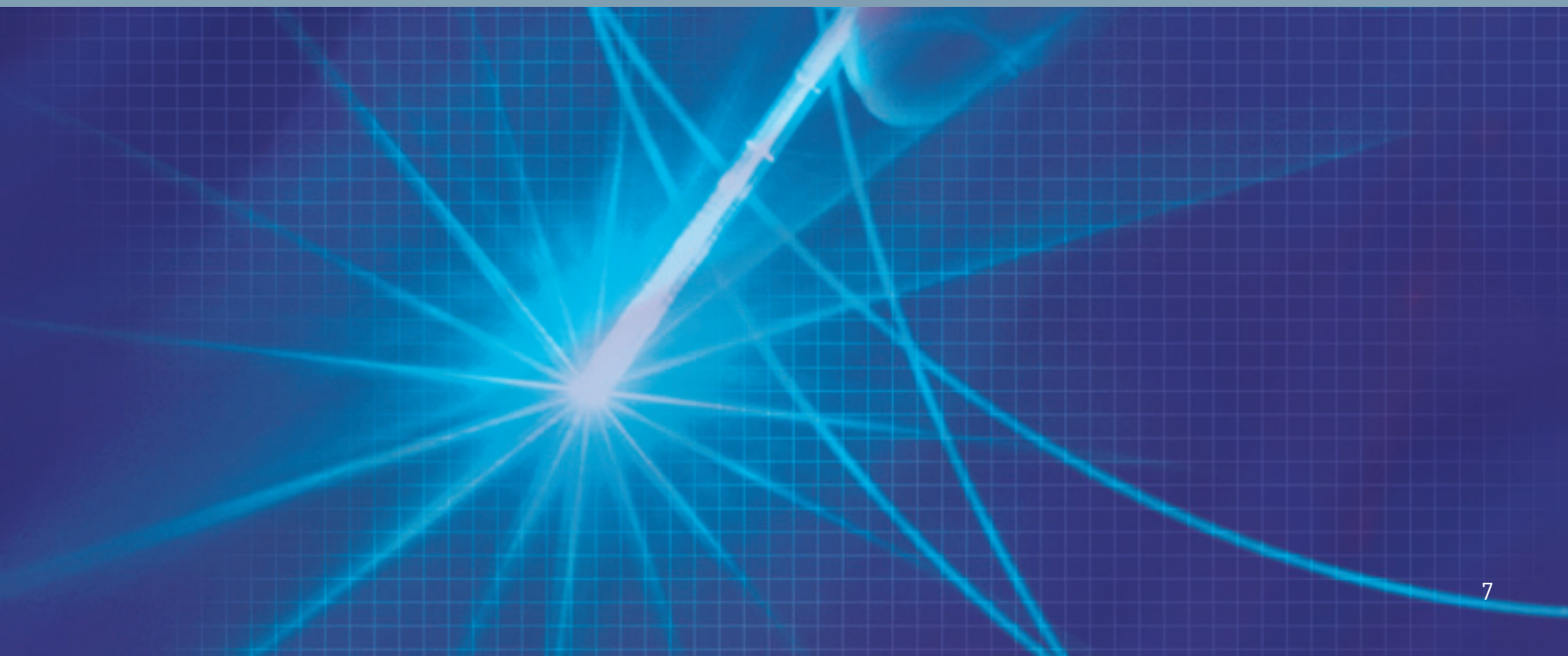

Viking 3 terminal blocks with screw connection and accessories





NEW

				ELECTRICAL FUNCTION	
0371 61 0371 63 0371 64 0371 66 0371 69 0371 68 0371 00 0371 08 0371 20 0371 30	Connecting (p. 14)	1 connection - 1 entry/1 outlet			
		1 connection - 2 entries/2 outlets			
		2 connections on 2 levels			
		3 connections on 3 levels			
0371 71 0371 76 0371 78 0371 79	For protection conductor (p. 14)	1 connection - 1 entry/1 outlet - metal base			
		1 connection - 1 entry/1 outlet - plastic base ⁽¹⁾			
		1 connection - 2 entries/2 outlets - metal base			
0371 80 0371 81 0371 84 0371 86 0371 87	Disconnect (p. 15)	1 connection	Open (to be equipped)		
			For fuse cartridge 5 x 20 with handle lever		
			For fuse cartridge 5 x 20 with handle lever + blown fuse indicator		
			For neutral circuit with handle lever		
			For standard circuit	With handle lever With mini lever	
			For circuit not broken	With handle lever With mini lever	
			For fuse cartridge 5 x 20 with screwed plug		
0371 53 0371 56	Function blocks (p. 15)	1 connection	Modular Diode carrier 1N4007		
		2 connections on 2 levels	Diode carrier 1N4007		
			With voltage presence LED		
0371 51 0371 52 0371 92	For sensors and actuator (p. 15) PNE (p. 14) Measurement (p. 15)	3 connections on 3 levels	Sensor		
			Actuator		
			Phase/Neutral/Earth		
		1 connection	Disconnect for measuring circuit		

(1) Can be used for protection conductor inside class II equivalent assemblies
 (2) Blown fuse indicator 12/24/48 V ~ Cat. No. 0375 24 or 110/250 V~ Cat. No. 0375 25
 (3) Or end stop Cat. No. 0375 10

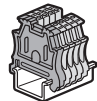
(4) Upper level only
 (5) Lower level only
 (6) Lower and intermediate levels

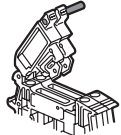
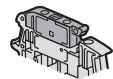
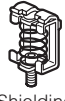
Red catalogue numbers: New products

TERMINAL BLOCK				INSULATION		EQUIPOTENTIAL LINK					PROTECTION		MEASURE- MENT	ASSOCIATED PRODUCTS											
Nominal cross-section (mm ²)	Width (mm)	Colour	Cat. Nos.	End cap	Separation / insulation divider	Comb for 2 blocks, auto. front	Comb for 3 blocks, auto. front	Comb for 10 blocks, auto. front	Comb for 12 blocks, side	Bar for 12 blocks, front	Single pole screen	Cut to length screen	Test socket												
2-5	5	0371 60	0375 50 ⁽³⁾	0375 60	0375 02	-	0375 01	-	-	-	0375 65	0375 68	0375 27	 End stops (p. 18)											
		0371 00																							
		0371 20																							
		0371 30																							
4	6	0371 61	0375 50 ⁽³⁾	0375 60	0375 05	-	0375 04	-	-	-	0375 65	0375 68	0375 27	 Label holder for end stop (p. 18)											
		0371 01																							
		0371 21																							
		0371 31																							
6	8	0371 62	0375 50 ⁽³⁾	0375 60	0375 08	0375 07	-	-	-	-	0375 66	0375 68	0375 27	 Handle lever / mini lever (p. 19)											
		0371 78																							
10	10	0371 63	0375 50 ⁽³⁾	0375 60	-	-	-	-	-	0375 40	0375 66	0375 68	0375 75												
		0371 03																							
16	12	0371 64	0375 51	0375 61	-	-	-	-	-	0375 42	0375 67	0375 69	0375 76												
		0371 04																							
35	15	0371 65	0375 51	0375 61	-	-	-	-	-	0375 44	0375 67	0375 69	0375 76												
		0371 05																							
70	22	0371 66	built-in	-	-	-	-	-	-	-	-	-	-	-											
4	6	0371 69	0375 52	0375 62	0375 05	-	0375 04	-	-	-	-	-	0375 27												
		0371 09																							
2-5	5	0371 67	0375 53	0375 63	0375 02	-	0375 01	-	-	-	-	-	0375 27 ⁽⁴⁾	 Joining rods for disconnect blocks (p. 19)											
		0371 07																							
4	6	0371 68	0375 53	0375 63	0375 05	-	0375 04	-	-	-	-	-	0375 27 ⁽⁴⁾												
		0371 08																							
2-5	5	0371 51	0375 54	0375 54	0375 02 ⁽⁴⁾	-	0375 01 ⁽⁴⁾	0375 46 ⁽⁶⁾	0375 47 ⁽⁶⁾	-	-	-	0375 27 ⁽⁴⁾												
2-5	5	0371 70	0375 50 ⁽³⁾	-	-	-	-	-	-	-	-	-	-												
4	6	0371 71																							
6	8	0371 72																							
10	10	0371 73																							
16	12	0371 74	0375 51	-	-	-	-	-	-	-	-	-	-												
35	15	0371 75																							
35	15	0371 76	-	-	-	-	-	-	-	-	-	-	-	-											
4	6	0371 77	0375 50	0375 60	0375 05	-	0375 04	-	-	-	0375 65	0375 68	-	 Blown fuse indicators (p. 19)											
6	8	0371 78	0375 50	0375 60	0375 08	0375 07	-	-	-	-	0375 66	0375 68	-												
4	6	0371 79	0375 52	-	-	-	-	-	-	-	-	-	-												
2-5	6	0371 80	0375 55	0375 62	0375 05	-	0375 04	-	-	-	-	-	0375 27	 Shielding (p. 19)											
		0371 81																							
		0371 81 + 0375 24 / 25 ⁽²⁾																							
		0371 82																							
		0371 83																							
		0371 84													0375 55	0375 62	0375 05	-	0375 04	-	-	-	-	-	0375 27
		0371 85													0375 55	0375 62	0375 05	-	0375 04	-	-	-	-	-	-
		0371 86													0375 55	0375 62	0375 05	-	0375 04	-	-	-	-	-	-
10	12	0371 87	0375 56	-	-	-	-	-	-	-	-	-	-												
2-5	5	0371 53	0375 55	-	0375 02	-	0375 01	-	-	-	-	-	0375 27												
		0371 54																							
4	6	0371 55	0375 53	0375 63	0375 05	-	0375 04	-	-	-	-	-	0375 27 ⁽⁴⁾												
		0371 56													0375 53	0375 63	0375 05 ⁽⁵⁾	-	0375 04 ⁽⁵⁾	-	-	-	-		
2-5	5	0371 51	0375 54	0375 54	0375 02 ⁽⁴⁾	-	0375 01 ⁽⁴⁾	0375 46 ⁽⁶⁾	0375 47 ⁽⁶⁾	-	-	-	0375 27 ⁽⁴⁾												
		0371 52																							
4	8	0371 92	0375 57	-	-	-	-	-	-	-	-	-	0375 77	 CAB 3 (p. 27)											

Viking 3 terminal blocks with spring connection and accessories





NEW

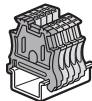

ELECTRICAL FUNCTION

0372 60 0372 61 0372 64 0372 40 0372 69 0372 68 0372 02 0372 47 0372 21 0372 42	<p>Connecting (p. 16)</p>	<p>1 connection - 2 cables - 1 entry/1 outlet</p> <p>1 connection - 3 cables - 1 entry/2 outlets</p> <p>1 connection - 4 cables - 2 entries/2 outlets</p> <p>2 connections - 4 cables - 2 levels</p>	
0372 70 0372 71 0372 72 0372 12	<p>For protection conductor (p. 16)</p>	<p>1 connection - 2 cables - 1 entry/1 outlet - metal base</p> <p>1 connection - 3 cables - 1 entry/2 outlets - metal base</p> <p>1 connection - 4 cables - 2 entries/2 outlets - metal base</p>	
0372 80 0372 82 0372 83 0372 84	<p>Disconnect (p. 17)</p>	<p>1 connection 2 cables</p> <p>Open (to be equipped)</p> <p>For fuse cartridge 5 x 20 with handle lever</p> <p>For fuse cartridge 5 x 20 with handle lever + blown fuse indicator</p> <p>For neutral circuit with handle lever</p> <p>For standard circuit</p> <p>For circuit not broken</p>	
0372 54	<p>Function blocks (p. 17)</p>	<p>1 connection 4 cables 2 entries/2 outlets</p> <p>Diode carrier 1N4007</p> <p>2 connections 4 cables 2 entries</p> <p>Diode carrier 1N4007</p> <p>With voltage presence LED</p>	

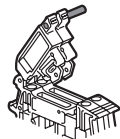
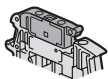
(1) Blown fuse indicator 12/24/48V~/~ Cat. No. 0375 24 or 110/250V~ Cat. No. 0375 25
 (2) Lower level only
 (3) Upper level only

TERMINAL BLOCK				INSULATION		EQUIPOTENTIAL LINK			MEASUREMENT	ASSOCIATED PRODUCTS							
Nominal cross-section (mm ²)	Width (mm)	Colour	Cat. Nos.	End cap	Separation and insulation divider	Comb for 2 blocks	Comb for 3 blocks	Comb for 10 blocks	Test socket								
4	5	● 0372 60	0375 86	0375 95	0375 02	-	0375 01	0375 27		End stops (p. 18)							
		● 0372 00															
		● 0372 20															
4	6	● 0372 61	built-in	0375 95	0375 05	-	0375 04	0375 27		Label holder for end stop (p. 18)							
		● 0372 01															
		● 0372 21															
6	8	● 0372 62	built-in	-	0375 08	0375 07	-	0375 27									
● 0372 02																	
10	10	● 0372 63	built-in	-	0375 82	-	-	-									
		● 0372 03															
16	12	● 0372 64	built-in	-	0375 85	-	-	-									
		● 0372 04															
4	5	● 0372 40	0375 87	0375 95	0375 02	-	0375 01	0375 27		Handle lever / mini lever (p. 19)							
		● 0372 41															
		● 0372 42															
4	6	● 0372 43	built-in	0375 95	0375 05	-	0375 04	0375 27									
		● 0372 44															
4	5	● 0372 46	0375 88	0375 95	0375 02	-	0375 01	0375 27		Joining rods for disconnect blocks (p. 19)							
		● 0372 47															
4	6	● 0372 69	built-in	-	0375 05	-	0375 04	0375 27									
		● 0372 09															
4	5	● 0372 67	0375 89	0375 96	0375 02	-	0375 01	0375 27 ⁽³⁾									
		● 0372 07															
4	6	● 0372 68	built-in	0375 96	0375 05	-	0375 04	0375 27 ⁽³⁾									
		● 0372 08															
4	5	● 0372 70	0375 86	-	-	-	-	-		Blown fuse indicators (p. 19)							
4	6	● 0372 71	built-in	-	-	-	-	-									
6	8	● 0372 72															
10	10	● 0372 73															
16	12	● 0372 74															
4	5	● 0372 10							0375 87	-	-	-	-	-			
4	6	● 0372 11	built-in	-	-	-	-	-		Shielding (p. 19)							
4	5	● 0372 12	0375 88	-	-	-	-	-									
4	6	● 0372 79	built-in	-	-	-	-	-									
4	5	● 0372 80	0375 90	-	0375 05	-	0375 04	0375 27									
2:5	6	● 0372 81	0375 90	-	0375 05	-	0375 04	-			CAB 3 (p. 27)						
		● 0372 81 + 0375 24/25 ⁽¹⁾															
		● 0372 82															
		● 0372 83															
		● 0372 84										0375 90	-	0375 05	-	0375 04	0375 27
		● 0372 85										0375 90	-	0375 05	-	0375 04	
		● 0372 86										0375 90	-	0375 05	-	0375 04	0375 27
4	5	● 0372 54	0375 88	0375 95	0375 02	-	0375 01	-									
		● 0372 55	0375 89	0375 96	0375 02	-	0375 01	-									
		● 0372 56	0375 89	0375 96	0375 02 ⁽²⁾	-	0375 01 ⁽²⁾	-									

Viking 3 heavy duty terminal blocks

	ELECTRICAL FUNCTION	TERMINAL BLOCK				INSULATION Separation and insulation divider	EQUIPOTENTIAL LINK Shunt	PROTECTION		ASSOCIATED PRODUCTS CAB 3 (p. 27)	
		Max. connection (mm ²)	Width (mm)	Cat. Nos.				Cover 4 blocks	Cover 3 blocks		
				Rail	Rail						
 0390 11 0390 21 0390 14 Power terminal blocks (p. 24)	Cable - cable		42	0390 10	–	–	0394 46	–	–		
			55	0390 11	–	–	0394 47	–	–		
	Cable lug - Cable lug		36	0390 13	–	–	0394 46	–	–		
			42	0390 14	–	–	0394 46	–	–		
	Cable lug - Cable		42	0390 17	–	–	0394 46	–	–		
			55	0390 18	–	–	0394 47	–	–		
	Cable - Cable lug		42	0390 20	–	–	0394 46	–	–		
			55	0390 21	–	–	0394 47	–	–		
	For busbars or eyelets		35	26	0390 71	0390 31	0394 77	–	0394 88		–
			70	34	0390 72	0390 32	0394 78	–	0394 86		–
			120	34	0390 73	0390 33	0394 78	–	0394 86		–
			240	46	0390 74	0390 34	0394 78	–	0394 89		0394 86

old range: Viking 3 terminal blocks and accessories and equivalences between old/new range

SCREW CONNECTION						SCREW CONNECTION (CONTINUED)									
		TERMINAL BLOCKS						TERMINAL BLOCKS							
		Nominal capacity (mm ²)	Width (mm)	Cat. Nos. (old range)	Cat. Nos. (new range)			Nominal capacity (mm ²)	Width (mm)	Cat. Nos. (old range)	Cat. Nos. (new range)				
Standard	1 connection		2-5	5	0390 60	0371 60	For neutral conductor	1 connection	2-5	5	0393 00	0371 00			
			4	6	0390 61	0371 61			4	6	0393 01	0371 01			
			6	8	0390 62	0371 62			6	8	0393 02	0371 02			
			10	10	0390 64	0371 63			10	10	–	0371 03			
			16	12	0390 66	0371 64			16	12	0393 04	0371 04			
			35	15	0390 68	0371 65			35	15	–	0371 05			
			70	22	0390 70	0371 66									
	1 connection - 1 entry - 2 outlets		4	6	0390 82	0371 69		2 connections - 2 levels	4	6	0393 07	0371 08			
	2 connections - 2 levels		2-5	5	0390 77	0371 67	For circuit not broken	1 connection	2-5	5	–	0371 20			
	3 connections - 3 levels		4	6	0390 78	0371 68		4	6	0393 39	0371 21				
			2-5	5	0390 51	0371 51		1 disconnect connection	4	6	0393 38	0371 85			
V.O. - UL 94	1 connection		2-5	5	0390 00	–	For sensor/actuator	3 connections 3 levels	Sensor/power supply unit	2-5	5	0390 51	0371 51		
			4	6	0390 01	–			Actuator/power supply unit	2-5	5	0390 52	0371 52		
			6	8	0390 02	–			PNE Phase/Neutral/Earth						
Function blocks	2 connections 2 levels	Shunted	4	6	0390 76	0371 69	For special circuits	1 connection - red	2-5	5	–	0371 30			
		Diode carrier	4	6	0390 80	0371 55		1 connection - red	4	6	–	0371 31			
		With voltage presence LED	4	6	–	0371 56									
		Disconnect	1 connection	Blade type	4	6		0390 84	0371 84	For protection conductor	1 connection - Metal base	2-5	5	0371 70	0371 70
				Neutral equipped	4	8		0390 85	0371 82			4	6	0371 71	0371 71
				For cartridge 5 x 20	10	12		–	0371 87			6	8	0393 72	0371 72
4	8				0390 86	0371 81	10	10	0393 74			0371 73			
		4	8	–	0371 81 +037525	16	12	0393 76	0371 74						
		4	8	0390 88	–	35	15	0393 78	0371 75						
	2 connections 2 levels	For cartridge 5 x 20	4	8	0390 88	–	2 connections - 2 levels - Metal base	4	6	0393 73	0371 79				
						1 connection - Plastic base	4	6	0393 81	0371 77					
						1 connection - Metal base - bare terminal	6	8	0393 82	0371 78					
									35	15	–	0371 76			

Red catalogue numbers: New products

old range: Viking 3 terminal blocks and accessories and equivalences between old/new range (continued)

SPRING CONNECTION				TERMINAL BLOCKS			
				Nominal capacity (mm ²)	Width (mm)	Cat. Nos. (old range)	Cat. Nos. (new range)
Standard	1 connection	2 cables		2-5	5	0396 01	0372 60
				4	6	0396 04	0372 61
				6	8	–	0372 62
				10	10	–	0372 63
	3 cables 1 entry - 2 outlets			2-5	5	0396 02	0372 40
				4	6	–	0372 43
	4 cables 1 entry - 2 outlets			2-5	5	0396 03	0372 46
				1-5	5	0396 27	0372 67
2 connections 2 levels	4 cables		4	6	0396 36	0372 68	
			2-5	5	–	0372 00	
For neutral conductor	1 connection	2 cables		4	6	–	0372 01
				6	8	–	0372 02
				10	10	–	0372 03
				16	12	–	0372 04
	3 cables 1 entry - 2 outlets			2-5	5	–	0372 41
				4	6	–	0372 44
	4 cables 1 entry - 2 outlets			2-5	5	–	0372 47
				4	6	–	0372 08
2 connections 2 levels	4 cables		4	6	–	0372 08	
			4	6	–	0372 84	
Disconnect	1 connection	2 cables	Blade type for cartridge 5 x 20	4	6	–	0372 81
				4	6	–	0372 81
Diode carrier	1 connection	4 cables		2-5	5	–	0372 54
For protection conductor	1 connection	2 cables		2-5	5	0396 21	0372 70
				4	6	0396 24	0372 71
				6	8	0396 25	0372 72
				10	10	–	0372 73
	3 cables 1 entry - 2 outlets			16	12	–	0372 74
				2-5	5	–	0372 10
	4 cables 1 entry - 2 outlets			4	6	0396 30	0372 11
				2-5	5	–	0372 12
2 connections 2 levels	4 cables		4	6	–	0372 79	

SCREW CONNECTION ACCESSORIES			
Cat.Nos. (old range)	Cat.Nos. (new range)	End cap	
0394 50	0375 50	Block with 1 connection - width 5-6	
0394 51	0375 55	Block with 1 connection - width 8-10	
0394 52	0375 51	Block with 1 connection - width 12-15	
0394 82	–	Block with 1 connection 1 entry/2 outlet - width 6	
0394 55	0375 53	Block with 2 connections - width 5-6	
0394 53	0375 54	Sensor/actuator block - 3 connections Cat. Nos. 0390 51/52	
0394 73	–	Block with 1 connection V.O. - UL 94 - width 5-6	
0394 74	–	Block with 1 connection V.O. - UL 94 - width 8-10	
0393 49	–	Disconnect terminal - 1 connection Cat. Nos. 0390 85/86	
0393 48	–	Disconnect terminal - 2 connections Cat. No. 0390 88	
0393 09	–	Neutral block - 1 connection - width 5-6	
0393 11	–	Neutral block - 1 connection - width 8-10	
0393 13	–	Neutral block - 1 connection - width 12-15	
0393 15	0375 53	Neutral block - 2 connections - width 5-6	
0393 46	–	Block for circuit not broken - 1 connection Cat. No. 0393 39	
0393 45	0375 55	Block for circuit not broken - 1 connection Cat. No. 0393 38	
0393 84	0375 52	Block for cond. protection - 2 connections Cat. No. 0393 73	
0393 87	–	Block for cond. protection - 1 connection Cat. No. 0393 81	
0393 88	–	Block for cond. protection - 1 connection Cat. No. 0393 82	
Separation/insulation divider			
0394 66	0375 60	Block with 1 connection width 5-6-8-10 and disconnect. width 6	
0394 69	0375 63	Blocks with 2 connections width 5-6	
0394 67	0375 62	Blocks with 1 connection width 12-15 and disconnect. width 8	
0394 53	0375 54	Blocks with 3 connections width 5	
Equipotential bridging comb			
0394 31	–	Width 5 - 12 blocks	
0394 20	0375 04	Width 6 - 12 blocks	
0394 21	–	Width 8 - 12 blocks	
0394 40	0375 02	Width 5 - 2 blocks	
0394 43	0375 05	Width 6 - 2 blocks	
0394 41	–	Width 5 - 3 blocks	
0394 44	–	Width 6 - 3 blocks	
0394 22	0375 47	Sens./act. - width 5 - blue - 12 blocks	
0394 23	0375 46	Sens./act. - width 5 - brown - 12 blocks	
0394 26	–	Sens./act. - width 5 - green - 12 blocks	
Equipotential bridging bar			
0394 10	0375 01	Insulated - width 5 - 12 blocks	
0394 11	0375 04	Insulated - width 6 - 12 blocks	
0394 12	–	Insulated - width 8 - 12 blocks	
0394 34	–	Insulated - width 5 - 2 blocks	
0394 37	0375 05	Insulated - width 6 - 2 blocks	
0394 35	–	Insulated - width 5 - 3 blocks	
0394 38	0375 02	Insulated - width 6 - 3 blocks	
0394 13	0375 40	Bare - width 10 - 12 blocks	
0394 14	0375 42	Bare - width 12 - 12 blocks	
0394 15	0375 44	Bare - width 15 - 12 blocks	
0394 16	0375 40	Bare - width 10 - 12 blocks - low spacer	
0394 17	0375 42	Bare - width 12 - 12 blocks - low spacer	
0394 18	0375 44	Bare - width 15 - 12 blocks - low spacer	
Protective screen			
0394 92	0375 65	Single pole for block with 1 connection - width 5-6	
0394 93	0375 66	Single pole for block with 1 connection - width 8-10	
0394 94	0375 67	Single pole for block with 1 connection - width 12-15	
0394 80	0375 68	Cut to length - width 5-6-8-10 (on Cat. No. 0394 66)	
0394 81	0375 69	Cut to length - width 12-15 (on Cat. No. 0394 67)	
Miscellaneous			
0394 05	0375 35	Screening continuity bracket for 1 connection blocks - width 5-6-8-10	
0394 95	–	Protection cap for separable combs/ bars - width 5-6	

END STOPS					
			Cat. Nos. (old range)	Cat. Nos. (new range)	
12 width end stop, tri-rail			0394 00	0375 13	
8 width end stop, rail □			0394 02	–	
8 width end stop, rail □			0394 03	0375 11	
10 width stop, bar support			–	0375 12	

SPRING CONNECTION ACCESSORIES					
Cat. Nos. (old range)	Cat. Nos. (new range)	End cap	Cat. Nos. (old range)	Cat. Nos. (new range)	Separation/insulation divider
0396 31	0375 66	Std term. block - 2 cables - width 5-6	0396 49	–	Block with 2 cables - width 5-6
0396 32	0375 67	Std term. block - 3 cables - width 5	0396 50	–	Block with 3 cables - width 5
0396 77	–	Std term. block - 3 cables - width 6	Equipotential bridging comb		
0396 33	0375 68	Std/diode term. block - 4 cables - width 5	0396 58	–	Block - width 5 - 2 poles
0396 48	0375 69	Std term. block - 4 cables - 2 levels - width 5	0396 59	–	Block - width 5 - 3 poles
0396 85	–	Std term. block - 4 cables - 2 levels - width 6	0396 60	–	Block - width 5 - 10 poles
0396 43	0375 66	Protection cond. term. block - 2 cables - width 5-6	0396 61	0375 05	Block - width 6 - 2 poles
			0396 62	–	Block - width 6 - 3 poles
			0396 63	–	Block - width 6 - 10 poles

Viking 3 terminal blocks with screw connection

NEW

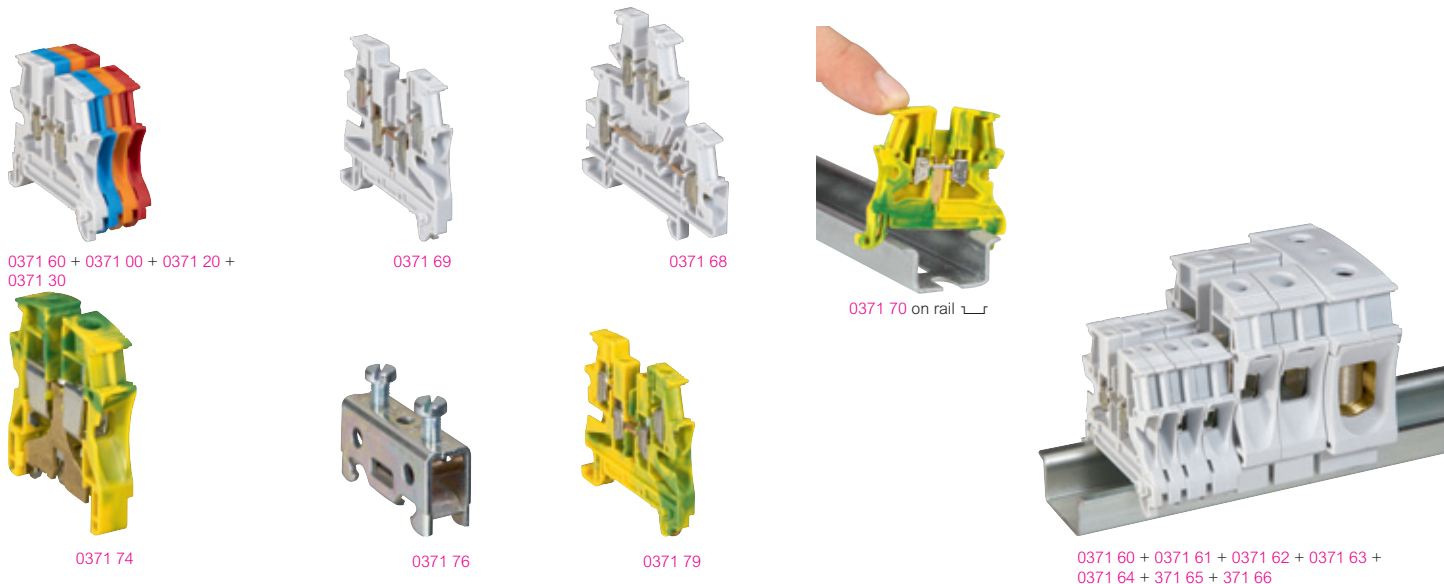

0371 60 + 0371 00 + 0371 20 + 0371 30

0371 69

0371 68

0371 70 on rail

0371 74

0371 76

0371 79

0371 60 + 0371 61 + 0371 62 + 0371 63 + 0371 64 + 371 65 + 371 66

Technical characteristics (p. 20)

Used to make the electrical connection between 2 rigid or flexible copper cables
 2 areas for bridging combs for alternating equipotential connection up to 8 width
 For rails depth 15 mm, EN 60715 depth 7.5 mm and 15 mm

Pack	Cat. Nos.	Connecting				
		Grey for standard circuit, blue for neutral conductor, orange for circuit not broken by the master isolating device, red for special circuits (safety, protected, etc)				
		1 connection - 1 entry/1 outlet				
		Colour	Nominal cross-section (mm ²)	Capacity Rigid cable (mm ²)	Capacity Flexible cable (mm ²)	Width (mm)
60	0371 60	Grey	2.5	0.25 to 4	0.25 to 2.5	5
60	0371 00	Blue				
60	0371 20	Orange				
60	0371 30	Red				
50	0371 61	Grey				
50	0371 01	Blue	4	0.25 to 6	0.25 to 4	6
50	0371 21	Orange				
50	0371 31	Red				
40	0371 62	Grey	6	0.5 to 10	0.25 to 6	8
40	0371 02	Blue				
30	0371 63	Grey	10	1.5 to 16	2.5 to 10	10
30	0371 03	Blue				
20	0371 64	Grey	16	1.5 to 25	4 to 16	12
20	0371 04	Blue				
20	0371 65	Grey	35	2.5 to 50	4 to 35	15
20	0371 05	Blue				
10	0371 66 ⁽¹⁾	Grey	70	25 to 95	16 to 70	22
25	0371 69	Grey	4	0.25 to 6	0.25 to 4	6
25	0371 09	Blue				
60	0371 67	Grey	2.5	0.25 to 4	0.25 to 2.5	5
60	0371 07	Blue				
60	0371 68	Grey	4	0.25 to 6	0.25 to 4	6
60	0371 08	Blue				
50	0371 51 ⁽²⁾	Grey	2.5	0.25 to 4	0.25 to 2.5	5

Pack	Cat. Nos.	For protection conductor				
		1 connection - 1 entry/1 outlet - metal base				
		Screwless fixing on rail up to 10 mm width PEN from 10 mm ²				
		Colour	Nominal cross-section (mm ²)	Capacity Rigid cable (mm ²)	Capacity Flexible cable (mm ²)	Width (mm)
60	0371 70	Green/yellow	2.5	0.25 to 4	0.25 to 2.5	5
50	0371 71	Green/yellow	4	0.25 to 6	0.25 to 4	6
40	0371 72	Green/yellow	6	0.5 to 10	0.25 to 6	8
30	0371 73	Green/yellow	10	1.5 to 16	2.5 to 10	10
10	0371 74	Green/yellow	16	1.5 to 25	4 to 16	12
10	0371 75	Green/yellow	35	2.5 to 50	4 to 35	15
10	0371 76	-	35	2.5 to 50	4 to 35	15
		1 connection - 2 entries/2 outlets - metal base				
		Screwless fixing on rail				
50	0371 79	Green/yellow	4	0.25 to 6	0.25 to 4	6
		1 connection - 1 entry/1 outlet - plastic base				
		Can be used for protection conductor inside class II equivalent assemblies				
50	0371 77	Green	4	0.25 to 6	0.25 to 4	6
40	0371 78	Green	6	0.5 to 10	0.25 to 6	8
		PNE - Phase/Neutral/Earth				
		3 connections on 3 levels - metal base				
		Green/yellow marking for the lower level Screwless fixing on rail				
50	0371 52 ⁽²⁾	Colour	Nominal cross-section (mm ²)	Capacity Rigid cable (mm ²)	Capacity Flexible cable (mm ²)	Width (mm)
		Grey	2.5	0.25 to 4	0.25 to 2.5	5

CAB 3 marking system

see p. 27

(1) Built-in end cap
 (2) Cable capacity: 2.5 mm² max. with equipotential bridging comb

Red catalogue numbers: New products

Viking 3 terminal blocks with screw connection (continued)

NEW

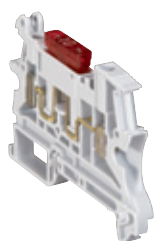

0371 80 + automotive-type fuse

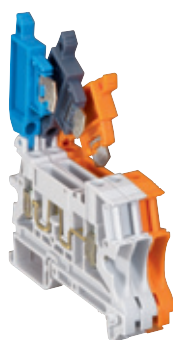

0371 82 + 0371 83 + 0371 85



0371 84 + 0371 86



0371 87

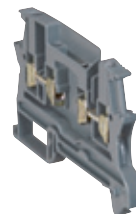

0371 53

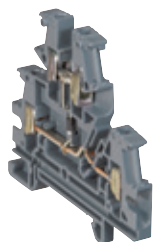

0371 55

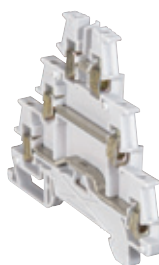

0371 51

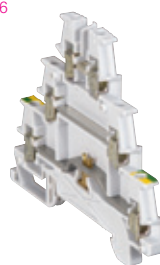

0371 52



0371 92

Technical characteristics (p. 20-21)

Used to make the electrical connection between 2 rigid or flexible copper cables
2 areas for bridging combs for alternating equipotential connection up to 8 width
For rails \perp depth 15 mm, \perp EN 60715 depth 7.5 mm and 15 mm

Pack	Cat. Nos.	Disconnect terminal blocks 1 connection			
		Disconnection by means of blade type lever, handle lever or mini lever (with tool)			
		Open (to be equipped)			
		Can take a blade-type automotive fuse or a miniature circuit breaker, or blade type levers Cat. Nos. 0375 15/16/17/18			
		Colour	Nominal cross-section (mm ²)	Capacity Rigid cable (mm ²) Flexible cable (mm ²)	Width (mm)
20	0371 80	Grey	2.5	0.25 to 2.5 0.25 to 2.5	6
20	0371 81	Grey	2.5	0.25 to 2.5 0.25 to 2.5	6
20	0371 82	Grey/blue	2.5	0.25 to 2.5 0.25 to 2.5	6
20	0371 83	Grey	2.5	0.25 to 2.5 0.25 to 2.5	6
20	0371 84	Grey	2.5	0.25 to 2.5 0.25 to 2.5	6
20	0371 85	Orange	2.5	0.25 to 2.5 0.25 to 2.5	6
20	0371 86	Orange	2.5	0.25 to 2.5 0.25 to 2.5	6
20	0371 87	Grey	10	0.25 to 16 0.25 to 10	12
20	0371 88	Grey	10	0.25 to 16 0.25 to 10	12

Blade type levers, joining rods and blown fuse indicators (p. 19)



New Starfix crimping tools

see p. 30

Pack	Cat. Nos.	Function blocks			
		1 connection - modular			
		Component connected with screws			
		Colour	Nominal cross-section (mm ²)	Capacity Rigid cable (mm ²) Flexible cable (mm ²)	Width (mm)
20	0371 53	Grey	2.5	0.25 to 4 0.25 to 2.5	5
		1 connection - diode carrier			
20	0371 54	Grey	2.5	0.25 to 4 0.25 to 2.5	5
		2 connections on 2 levels - diode carrier			
60	0371 55	Grey	4	0.25 to 6 0.25 to 4	6
		2 connections on 2 levels - with LED			
		Voltage presence indicator (12/24V _~ / ~)			
60	0371 56	Grey	4	0.25 to 6 0.25 to 4	6
		For sensors and actuators			
		For connecting sensors (Cat. No. 0371 51) or actuators (Cat. No. 0371 52), and their shared power supply unit using equipotential bridging comb Cat. Nos. 0375 46/47 (wiring diagram p. 21)			
		3 connections on 3 levels - for sensor			
		Colour	Nominal cross-section (mm ²)	Capacity Rigid cable (mm ²) Flexible cable (mm ²)	Width (mm)
50	0371 51 ⁽¹⁾	Grey	2.5	0.25 to 4 0.25 to 2.5	5
		3 connections on 3 levels - for actuator			
		Green/yellow marking for the lower level Metal base. Screwless fixing on rail			
50	0371 52 ⁽¹⁾	Grey	2.5	0.25 to 4 0.25 to 2.5	5
		Disconnect for measurement			
		1 connection			
		With its accessories, allows intervention (measurements, maintenance, etc) on a current, voltage and power measuring circuit by keeping the current transformer secondary circuit closed			
		Colour	Nominal cross-section (mm ²)	Capacity Rigid cable (mm ²) Flexible cable (mm ²)	Width (mm)
25	0371 92	Grey	4	0.25 to 4 0.25 to 4	8

Accessories (p. 18)

End stops (p. 18)

(1) Rigid cable capacity: 2.5 mm² max with equipotential bridging comb

Viking 3 terminal blocks with spring connection

NEW



0372 60 + 0372 00 + 0372 20



0372 01



0372 21



0372 63



0372 40

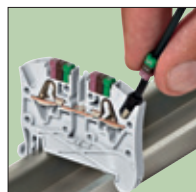

Automatic insertion of stripped cable with ferrule cap or rigid cable up to width of 6 mm

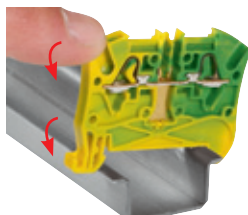

0372 70 Automatic fixing on rail



0372 72



0372 79



Technical characteristics (p. 22)

Screwless connection system, stainless steel spring type
 Used to make the electrical connection between 2 rigid copper cables, or flexible cables with or without ferrules (p. 30)
 Direct tool-free insertion of a rigid cable or flexible cable with ferrule, up to 6 mm width
 2 areas for bridging combs for alternating equipotential connection
 For rails \perp depth 15 mm, \perp EN 60715 depth 7.5 mm and 15 mm

Pack	Cat. Nos.	Connecting					Width (mm)
		Grey for standard circuit, blue for neutral conductor, orange for circuit not broken by the master isolating device					
		1 connection - 2 cables - 1 entry/1 outlet					
			Capacity				
		Colour	Nominal cross-section (mm ²)	Rigid cable (mm ²)	Flexible cable (mm ²)	Flexible cable with ferrule (mm ²)	
60	0372 60	Grey	4	0.5 to 6	0.5 to 4	0.5 to 2.5	5
60	0372 00	Blue	4	0.5 to 6	0.5 to 4	0.5 to 2.5	5
60	0372 20	Orange	4	0.5 to 6	0.5 to 4	0.5 to 2.5	5
50	0372 61 ⁽¹⁾	Grey	4	0.5 to 6	0.5 to 4	0.5 to 4	6
50	0372 01 ⁽¹⁾	Blue	4	0.5 to 6	0.5 to 4	0.5 to 4	6
50	0372 21 ⁽¹⁾	Orange	4	0.5 to 6	0.5 to 4	0.5 to 4	6
50	0372 62 ⁽¹⁾	Grey	6	0.5 to 6	0.5 to 6	0.5 to 6	8
50	0372 02 ⁽¹⁾	Blue	6	0.5 to 6	0.5 to 6	0.5 to 6	8
40	0372 63 ⁽¹⁾	Grey	10	0.75 to 10	0.75 to 10	0.75 to 10	10
40	0372 03 ⁽¹⁾	Blue	10	0.75 to 10	0.75 to 10	0.75 to 10	10
10	0372 64 ⁽¹⁾	Grey	16	4 to 16	4 to 16	4 to 16	12
10	0372 04 ⁽¹⁾	Blue	16	4 to 16	4 to 16	4 to 16	12
		1 connection - 3 cables - 1 entry/2 outlets					
60	0372 40	Grey	4	0.5 to 6	0.5 to 4	0.5 to 2.5	5
60	0372 41	Blue	4	0.5 to 6	0.5 to 4	0.5 to 2.5	5
60	0372 42	Orange	4	0.5 to 6	0.5 to 4	0.5 to 2.5	5
50	0372 43 ⁽¹⁾	Grey	4	0.5 to 6	0.5 to 4	0.5 to 4	6
50	0372 44 ⁽¹⁾	Blue	4	0.5 to 6	0.5 to 4	0.5 to 4	6
		1 connection - 4 cables - 2 entries/2 outlets					
60	0372 46	Grey	4	0.5 to 6	0.5 to 4	0.5 to 2.5	5
60	0372 47	Blue	4	0.5 to 6	0.5 to 4	0.5 to 2.5	5
50	0372 69 ⁽¹⁾	Grey	4	0.5 to 6	0.5 to 4	0.5 to 4	6
50	0372 09 ⁽¹⁾	Blue	4	0.5 to 6	0.5 to 4	0.5 to 4	6
		2 connections - 4 cables - 2 levels					
60	0372 67	Grey	4	0.5 to 6	0.5 to 4	0.5 to 2.5	5
60	0372 07	Blue	4	0.5 to 6	0.5 to 4	0.5 to 2.5	5
50	0372 68 ⁽¹⁾	Grey	4	0.5 to 6	0.5 to 4	0.5 to 4	6
50	0372 08 ⁽¹⁾	Blue	4	0.5 to 6	0.5 to 4	0.5 to 4	6

Pack	Cat. Nos.	For protection conductor					Width (mm)
		Metal base Screwless fixing on rail PEN from 10 mm ²					
		1 connection - 2 cables - 1 entry/1 outlet					
			Capacity				
		Colour	Nominal cross-section (mm ²)	Rigid cable (mm ²)	Flexible cable (mm ²)	Flexible cable with ferrule (mm ²)	
60	0372 70	Green/yellow	4	0.5 to 6	0.5 to 4	0.5 to 2.5	5
50	0372 71 ⁽¹⁾	Green/yellow	4	0.5 to 6	0.5 to 4	0.5 to 4	6
25	0372 72 ⁽¹⁾	Green/yellow	6	0.5 to 6	0.5 to 6	0.5 to 6	8
20	0372 73 ⁽¹⁾	Green/yellow	10	0.75 to 10	0.75 to 10	0.75 to 10	10
15	0372 74 ⁽¹⁾	Green/yellow	16	4 to 16	4 to 16	4 to 16	12
		1 connection - 3 cables - 1 entry/2 outlets					
40	0372 10	Green/yellow	4	0.5 to 6	0.5 to 4	0.5 to 2.5	5
30	0372 11 ⁽¹⁾	Green/yellow	4	0.5 to 6	0.5 to 4	0.5 to 4	6
		1 connection - 4 cables - 2 entries/2 outlets					
40	0372 12	Green/yellow	4	0.5 to 6	0.5 to 4	0.5 to 2.5	5
30	0372 79 ⁽¹⁾	Green/yellow	4	0.5 to 6	0.5 to 4	0.5 to 4	6

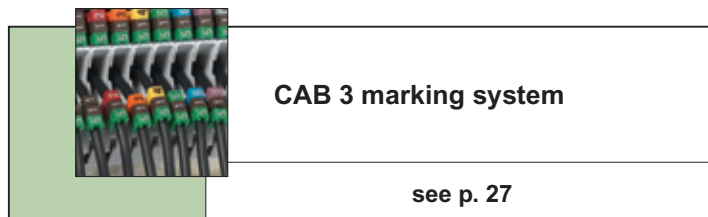

(1) Built-in end cap

Viking 3 terminal blocks with spring connection (continued)

NEW

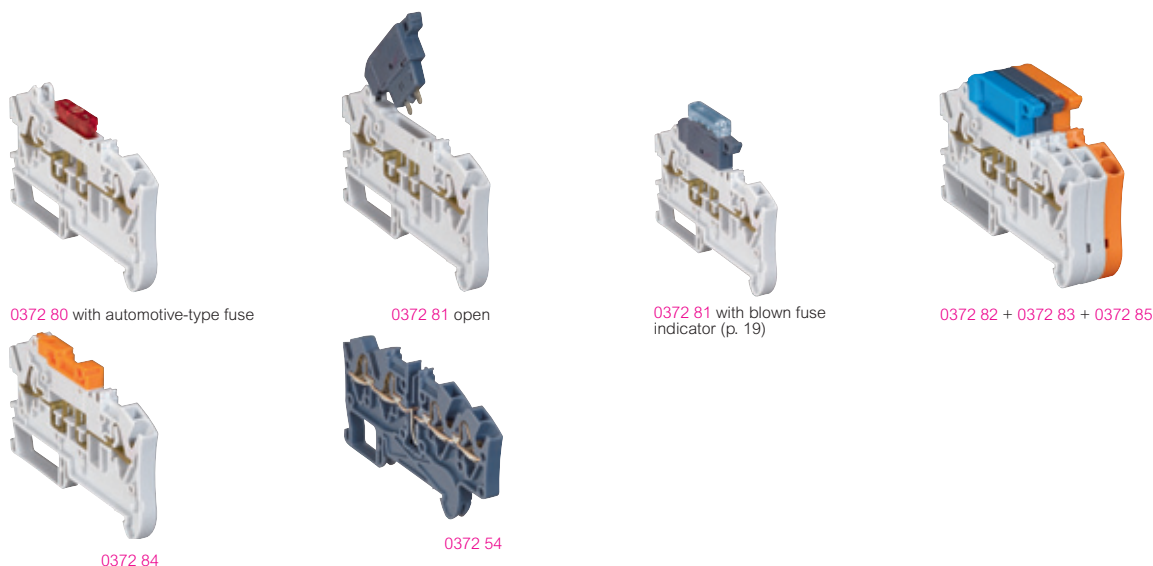

Technical characteristics (p. 22)

Screwless connection system, stainless steel spring type
 Used to make the electrical connection between 2 rigid copper cables, or flexible cables with or without ferrule (p. 30)
 Direct tool-free insertion of a rigid cable or flexible cable with ferrule, up to 6 mm width
 2 areas for bridging combs for alternating equipotential connection
 For rails \perp depth 15 mm, \perp EN 60715 depth 7.5 mm and 15 mm

Pack	Cat. Nos.	Disconnect terminal blocks 1 connection - 2 cables					
		Disconnection by means of blade type lever, handle lever or mini lever (with tool)					
		Open (to be equipped) Can take a blade-type automotive fuse or a miniature circuit breaker, blade type levers Cat. Nos. 0375 15/16/17/18					
		Colour	Nominal cross-section (mm ²)	Rigid cable (mm ²)	Capacity Flexible cable (mm ²)	Flexible cable with ferrule (mm ²)	Width (mm)
20	0372 80	Grey	2.5	0.5 to 2.5	0.5 to 2.5	0.5 to 2.5	6
20	0372 81	Grey	2.5	0.5 to 2.5	0.5 to 2.5	0.5 to 2.5	6
20	0372 82	Grey/blue	2.5	0.5 to 2.5	0.5 to 2.5	0.5 to 2.5	6
20	0372 83	Grey	2.5	0.5 to 2.5	0.5 to 2.5	0.5 to 2.5	6
20	0372 84	Grey	2.5	0.5 to 2.5	0.5 to 2.5	0.5 to 2.5	6
20	0372 85	Orange	2.5	0.5 to 2.5	0.5 to 2.5	0.5 to 2.5	6
20	0372 86	Orange	2.5	0.5 to 2.5	0.5 to 2.5	0.5 to 2.5	6

Pack	Cat. Nos.	Function blocks					
		1 connection - 4 cables - 2 entries/2 outlets - diode-carrier					
60	0372 54	Colour Grey	Nominal cross-section (mm ²) 4	Rigid cable (mm ²) 0.5 to 6	Capacity Flexible cable (mm ²) 0.5 to 4	Flexible cable with ferrule (mm ²) 0.5 to 2.5	Width (mm) 5
60	0372 55	Grey	4	0.5 to 6	0.5 to 4	0.5 to 2.5	5
		2 connections - 4 cables - 2 levels - diode carrier					
60	0372 56	Grey	4	0.5 to 6	0.5 to 4	0.5 to 2.5	5
		2 connections - 4 cables - 2 levels - with LED Voltage presence indicator (12/24V _± / ~)					
60	0372 56	Grey	4	0.5 to 6	0.5 to 4	0.5 to 2.5	5

Accessories (p. 18)

End stops (p. 18)

Blade type levers, joining rods and blown fuse indicators (p. 19)



Viking 3 accessories for terminal blocks

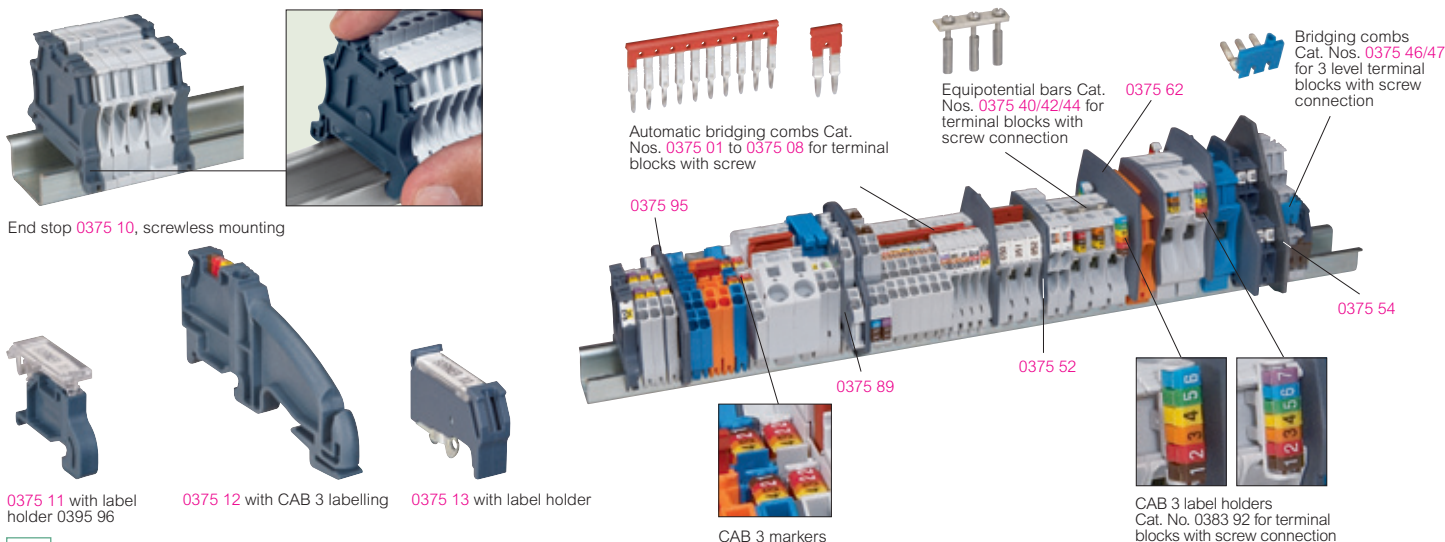

Technical characteristics (p. 23)

Pack	Cat. Nos.	Rails for cutting to length
10	0374 04	Length 2 m
10	0374 07	EN 60715 depth 7.5 mm
		depth 15 mm
10	0394 49	45° mounting bracket Set of 2 supports for tilting a rail at an angle of 45° Supplied with 4 x M6 screws, nuts and washers
50	0375 10	End stops Accept CAB 3 markers Automatic 6 mm width Screwless mounting For rails EN 60715 depth 15 mm and EN 60715 depth 7.5 mm and 15 mm Accepts label holder Cat. No. 0395 96 Acts as end cap for screw terminal blocks 1 entry/1 outlet 5, 6, 8 and 10 mm width
20	0375 11	8 mm width For rails EN 60715 depth 15 mm and EN 60715 depth 7.5 mm and 15 mm Accepts label holder Cat. No. 0395 96
10	0375 12	10 mm width For rails EN 60715 depth 15 mm and EN 60715 depth 7.5 mm (except for rail fixed on plate) and 15 mm For supporting protection conductor bar: - Brass bar Cat. Nos. 0373 00/01 - Copper bar 12 x 4 mm with clamps Cat. No. 0373 02 - IP 2X terminal block with flat steel bar 12 x 2 mm Cat. No. 0048 19 - Copper bar 12 x 4 mm Cat. No. 0373 49 or 0373 89 - Shielding bar 10 x 3 mm Cat. No. 0375 34
20	0375 13	12 mm width For rails EN 60715, EN 60715 depth 15 mm and EN 60715 depth 7.5 mm and 15 mm After cutting out the upper divider, can be labelled
20	0395 96	Identification accessories Transparent label holder with variable angle Fixing on end stops Cat. Nos. 0375 10/11 Supplied with label 32 x 9.5 mm Can take label Cat. No. 0395 97
20	0395 97	Label for engraving 28 x 9.5 mm For label holder Cat. No. 0395 96. Flexible ABS White background, black engraving
10	0395 98	Black felt tip pen for permanent marking

Pack	Cat. Nos.	End caps
		Grey
100	0375 50	For screw terminal blocks 1 entry/1 outlet 5, 6, 8 and 10 mm width
20	0375 51	1 entry/1 outlet 12 and 15 mm width
20	0375 52	2 entries/2 outlets
20	0375 53	2 levels
20	0375 54	3 levels
20	0375 55	Disconnect terminal 6 mm width and function blocks 5 mm width
20	0375 56	Disconnect terminal fuse cartridge 5 x 20 with screwed plug
10	0375 57	Disconnect for measurement
50	0375 86	For spring terminal blocks with 5 mm width Allows the block to become 6 mm width and take a flexible cable fitted with a ferrule 4 mm ²
50	0375 87	1 entry/1 outlet
20	0375 88	1 entry/2 outlets
20	0375 89	2 entries/2 outlets
20	0375 89	2 levels
20	0375 90	For spring terminal blocks with 6 mm width Disconnect type
20	0375 60	Separation and insulation dividers Grey
10	0375 61	For screw terminal blocks 1 entry/1 outlet 5, 6, 8 and 10 mm width
10	0375 62	1 entry/1 outlet 12 and 15 mm width
10	0375 62	2 entry/2 outlets and disconnect 6 mm width blocks
10	0375 63	2 levels
20	0375 54	3 levels
10	0375 95	For spring terminal blocks 1 entry/1 outlet, 1 entry/2 outlets and 2 entry/2 outlets 5 and 6 mm width
10	0375 96	2 levels
20	0375 01 ⁽¹⁾	Equipotential bridging accessories Bridging combs for screw and spring terminal blocks Front mounting (automatic insertion), screwless Isolated and separable. Consecutive or alternating connection. Red
50	0375 02 ⁽¹⁾	For 10 blocks with 5 mm width
20	0375 04 ⁽¹⁾	For 2 blocks with 5 mm width
50	0375 05 ⁽¹⁾	For 10 blocks with 6 mm width
20	0375 07 ⁽¹⁾	For 2 blocks with 6 mm width
20	0375 08 ⁽¹⁾	For 3 blocks with 8 mm width
20	0375 08 ⁽¹⁾	For 2 blocks with 8 mm width

(1) Blocks Cat. Nos. 0371 51/52: upper level only
Block Cat. No. 0372 56: lower level only

Viking 3 accessories for terminal blocks (continued)

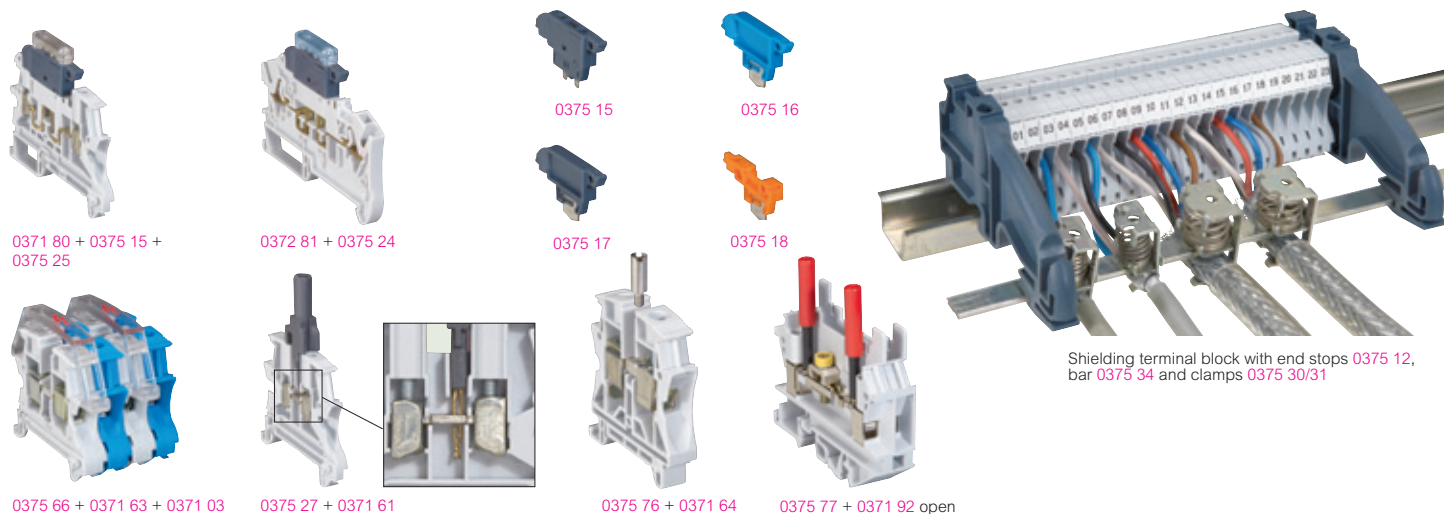

Technical characteristics (p. 22)

Pack	Cat. Nos.	Equipotential bridging accessories (continued)	Pack	Cat. Nos.	Shielding accessories (continued)
10	0375 40	Bars for screw terminal blocks Front mounting with screws. Pre-assembled Consecutive or alternating connection	10	0375 34	Ensure safe, simple connection of cable shielding Shielding bar For screw and spring terminal blocks. Steel. Length 1 m. For use with end stops Cat. No. 0375 12 10 x 3 mm
10	0375 42 ⁽¹⁾	For 12 blocks with 10 mm width	50	0375 35	Screening continuity bracket For screw terminal blocks 1 entry/1 outlet 5, 6, 8 and 10 mm width Connected with 2·8 x 0·8 mm clips or welded on. Capacity: 1 mm ²
10	0375 44	For 12 blocks with 12 mm width			Protective screens
		Bridging combs for 3-level screw terminal blocks For lower and intermediate levels of blocks Cat. Nos. 0371 51/52. Side mounting Isolated and separable			1 pole For screw terminal blocks 1 entry/1 outlet 5 and 6 mm width 8 and 10 mm width 12 and 15 mm width
10	0375 46	Brown. For 12 blocks with 5 mm width	10	0375 65	Cut to length Length 1 m Mounted on separation and insulation divider For screw terminal blocks 1 entry/1 outlet
10	0375 47	Blue. For 12 blocks with 5 mm width	10	0375 66	5, 6, 8 and 10 mm width (divider Cat. No. 0375 60)
		Bridging combs for spring terminal blocks Front mounting (automatic insertion), screwless Isolated. Red	10	0375 67	12 and 15 mm width (divider Cat. No. 0375 61)
20	0375 82	For 2 blocks with 10 mm width			Measurement accessories
20	0375 85	For 2 blocks with 12 mm width	10	0375 27 ⁽²⁾	For screw and spring terminal blocks Measurement socket for Ø4 mm plug for blocks with 5 and 6 mm width
		Accessories for disconnect blocks For screw and spring terminal blocks	50	0375 75	For screw terminal blocks Measurement socket for Ø2 mm plug for blocks with 10 mm width Cat. Nos. 0371 03/63
		Blade type levers For open blocks Cat. Nos. 0371 80 and 0372 80 Manual disconnection for handle type, tool required for mini lever type	20	0375 76	Measurement socket for Ø4 mm plug for blocks with 12 and 15 mm width Cat. Nos. 0371 04/05/64/65
10	0375 15	With handle lever for fuse cartridge 5 x 20	10	0375 77	Measurement socket for Ø4 mm plug for disconnect block for measurement Cat. No. 0371 92
10	0375 16	Blue handle lever for neutral			
10	0375 17	Grey handle lever			
10	0375 18	Mini lever			
		Joining rods For handle and mini lever			
20	0375 21	For 2 blocks			
20	0375 22	For 3 blocks			
		Blown fuse indicators Clip directly on to blocks Cat. Nos. 0371 81, 0372 81 or handle lever 0375 15 (with power off)			
10	0375 24	12/24/48 V _~ /~ for block with fuse cartridge 5 x 20 with handle lever			
10	0375 25	110/250 V _~ for block with fuse cartridge 5 x 20 with handle lever			
		Shielding accessories Ensure safe, simple connection of cable shielding			
		Shielding clamps For screw and spring terminal blocks - mounted by pivoting on collector bar 10 x 3 mm Cat. No. 0375 34 - mounted on plate with M4 screws (supplied) - mounted on rail with Cat. No. 0364 69			
10	0375 30	For cable diameter 3 to 8 mm			
10	0375 31	For cable diameter 4 to 13·5 mm			
4	0375 32	For cable diameter 10 to 20 mm			

(1) Except for Cat. No. 0371 87
(2) Except for disconnect blocks with handle lever, screw terminal block with LED and spring function blocks. 2 and 3-level terminal blocks: upper level only

Viking 3 terminal blocks with screw connection

Characteristics and dimensions (mm)

V2 polyamide according to UL 94, 960°C according to IEC EN 60695-2-11

Connecting blocks

Cat. Nos.	Voltage (V)			Current (A)				Nominal cross-section		
	IEC	CSA	UL	Ie	IEC		UL	IEC (mm²)		
					CSA	UL		IEC (mm²)	CSA (AWG)	UL (AWG)
0371 00/20/30/60	800	600	600	27	24	20	20	2.5	12	12
0371 01/21/31/61				36	32	30	30	4	10	10
0371 02/62				48	41	50	50	6	8	8
0371 03/63				63	57	60	60	10	6	6
0371 04/64				85	76	85	85	16	4	4
0371 05/65				138	125	115	115	35	2	2
0371 07/67				27	24	20	20	2.5	12	12
0371 08/68				36	32	30	30	4	10	10
0371 09/69				36	32	30	30	4	10	10
0371 66				1000	600	600	213	192	200	200
0371 77	800	600	600	36	32	30	30	4	10	10
0371 78				48	41	50	50	6	8	8

Cat. No. 0371 51: see blocks for sensors
IEC 60947-7-1, CSA no. 22-2 no. 158, UL 1059
Ie: Rated current NF C 15100 table 52H, column 4

Cat. Nos. 0371 00/01/
02/03/20/21/30/31/60/
61/62/63/77/78

Cat. Nos.
0371 04/05/64/65

Cat. No. 0371 66

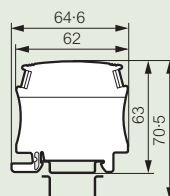
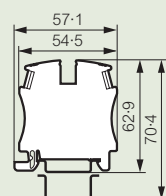
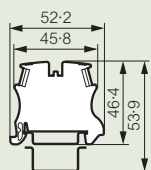

Cat. Nos. 0371 09/69

Cat. Nos. 0371 07/08/67/68

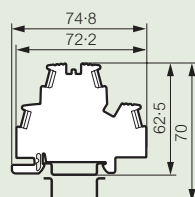
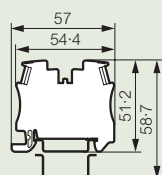

Approved by ATEX:
LCIE 07 ATEX 0010 U-0081 Ex II 1 or 2 G or D Ex e/i/tD/iD II

The terminal blocks with screw connection covered by this certificate are 1-, 2- and 3-level connecting terminal blocks, and blocks for protection conductor with metal⁽¹⁾ and plastic base (detailed list on p. 8)

The main characteristics are:

Operating temperature: - 30°C to + 55°C

Maximum temperature of materials: + 85°C

Working voltage acc. to EN 60079-7: 1-level terminal blocks: 500 V
Blocks with 2 entries - 2 outlets: 250 V
2 and 3-level terminal blocks: 250 V

Rated current:

Conductor cross-section (mm²)	2.5	4	6	10	16	35	70
Rated current (A)	18	23	30	42	57	93	144

Certificate of conformity of component for the customer is available on request

(1) Except for Cat. No. 0371 76

Blocks for protection conductor

Cat. Nos.	Voltage (V)			Nominal cross-section					
	IEC	CSA	UL	IEC (mm²)	CSA (AWG)	UL (AWG)			
0371 70	800	600	600	2.5	12	12			
0371 71				4	10	10			
0371 72				6	8	8			
0371 73 ⁽¹⁾				10	6	6			
0371 74 ⁽¹⁾				16	4	4			
0371 75 ⁽¹⁾				35	2	2			
0371 76				-	-	-	35	-	-
0371 77				800	600	600	4	10	10
0371 78				800	600	600	6	8	8
0371 79				500	300	300	4	10	10

IEC 60947-7-1/7-2, CSA no. 22-2 no. 158, UL 1059

(1) PEN terminal blocks

Cat. Nos.

0371 70/71/72/73

Cat. Nos. 0371 74/75

Cat. No. 0371 76

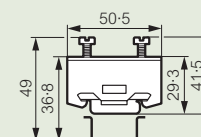
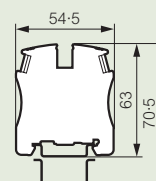
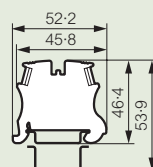

Cat. Nos. 0371 77/78

Cat. No. 0371 79

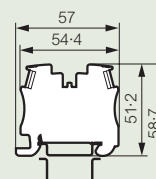
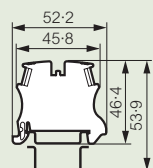

Disconnect terminals

Cat. Nos.	Voltage (V)			Current (A)			Nominal cross-section		
	IEC	CSA	UL	IEC	CSA	UL	IEC (mm²)	CSA (AWG)	UL (AWG)
0371 80	500	300	300	15	15	15	2.5	12	12
0371 81 or 0371 80 + 0375 15	250	250	250	6.3	6.3	6.3			
0371 82	500	300	300	15	15	15			
0371 83									
0371 84									
0371 85									
0371 86	250	250	250	10	10	10			
0371 87									

IEC 60947-7-1/7-3, CSA no. 22-2 no. 158, UL 1059

Power according to EN 60947-7-3

Cat. Nos.	Short-circuit		Short-circuit + overload	
	Separate blocks	Assembled blocks	Separate blocks	Assembled blocks
0371 81 or 0371 80 + 0375 15 ⁽¹⁾	4 W / 6.3 A	1.6 W/6.3 A	1.6 W/6.3 A	-
0371 87	Pvk = 4.75 W	Pvk = 2 W	Pv = 1.65 W	-
	4 W	2.5 W	1.6 W	-
	Pvk = 5 W	Pvk = 2.7 W	Pv = 1.8 W	-

(1) With or without blown fuse indicator Cat. No. 0375 25

Cat. No. 0371 80

Cat. Nos. 0371 81/82/83/85

Cat. Nos. 0371 84/86

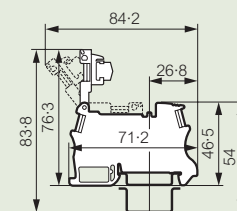
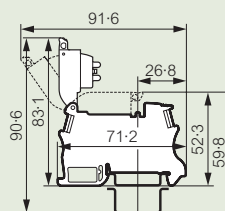
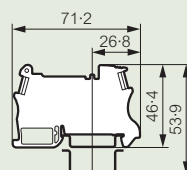

Cat. No. 0371 87

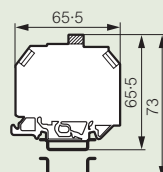

Function blocks

Cat. Nos.	Voltage (V)			Current (A)			Nominal cross-section		
	IEC	CSA	UL	IEC	CSA	UL	IEC (mm ²)	CSA (AWG)	UL (AWG)
0371 53	250	-	-	-	-	-	2.5	-	-
0371 54	250	-	-	1	-	-	2.5	-	-
0371 55	500	300	300	1	1	1	4	10	10
0371 56	12 to 24	12 to 24	12 to 24	32	30	30	4	10	10

IEC 60947-7-1, CSA no. 22-2 no. 158, UL 1059

Cat. Nos. 0371 53/54

Cat. Nos. 0371 55/56

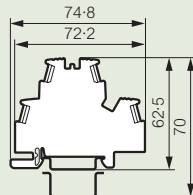
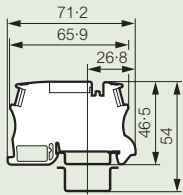

Schematic diagrams

Cat. No. 0371 53

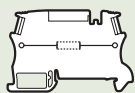

Cat. No. 0371 54

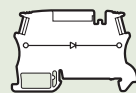

Cat. No. 0371 55

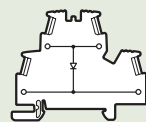

Cat. No. 0371 56

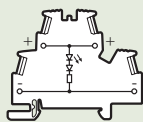

Diode for Cat. Nos. 0371 54/55
 - 1N4007 type 1A
 - direct current = 1 A
 - peak inverse voltage 1000 V
 - inverse current 5 µA at 25°C

Blocks for sensors and actuators/PNE

Cat. Nos.	Voltage (V)			Current (A)			Nominal cross-section			
	IEC	CSA	UL	I _e	IEC	CSA	UL	IEC (mm ²)	CSA (AWG)	UL (AWG)
0371 51	400	300	300	27	24	20	20	2.5	12	12
0371 52	-	-	-	-	-	-	-	-	-	-

IEC 60947-7-1/7-2, CSA no. 22-2 no. 158, UL 1059
 I_e: Rated current NF C 15100 table 52H, column 4

Cat. Nos. 0371 51/52

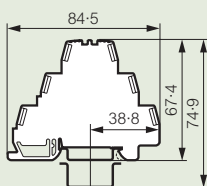

Wiring diagram

Block for sensor Cat. No. 0371 51

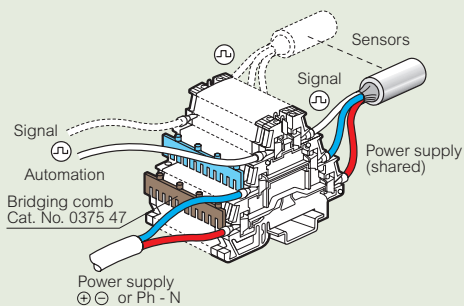

Block for actuator Cat. No. 0371 52

PNE block Cat. No. 0371 52

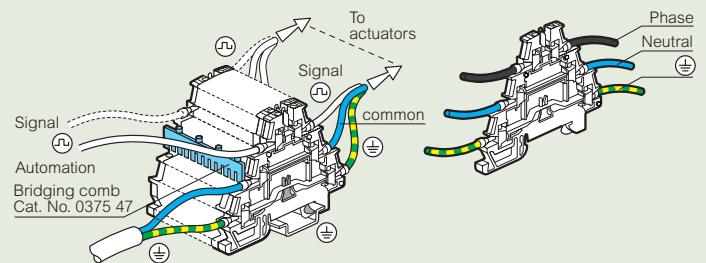

Disconnect block for measurement

Cat. Nos.	Voltage (V)			Current (A)			Nominal cross-section		
	IEC	CSA	UL	IEC	CSA	UL	IEC (mm ²)	CSA (AWG)	UL (AWG)
0371 92	800	-	-	24	-	-	4	-	-

IEC EN 60947-7-1

Cat. No. 0371 92

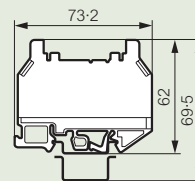

Wiring diagram for measurement blocks Cat. No. 0371 92

Ammeter circuit

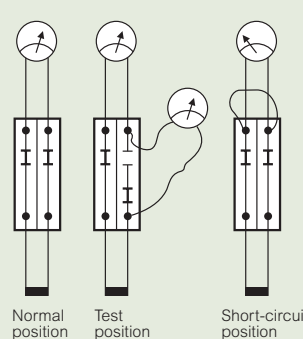

Wattmeter circuit

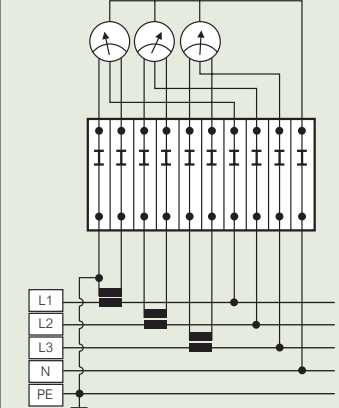

Per circuit:
 2 x Disconnect blocks for measurement Cat. No. 0371 92
 4 x Measurement sockets for Ø4 mm plug Cat. No. 0375 77
 1 x End cap Cat. No. 0375 57
 1 x Shunt with Ø4 mm plugs

10 x Disconnect blocks for measurement Cat. No. 0371 92
 12 x Measurement sockets for Ø4 mm plug Cat. No. 0375 77
 1 x End cap Cat. No. 0375 57
 3 x Shunts with Ø4 mm plugs

Stripped lengths (mm)

Screw terminal width (mm)	Rigid or flexible cable
5	
6	6 to 8
8	10 to 12
10	13 to 17
12	14 to 18
15	15 to 22
22	

Protection against fire and panic risks in public buildings/UTE C 12-201 guide

Art. EL 3, definitions: "Security installations are those that have to be put into or maintained in service to ensure the evacuation of the public" or facilitate the intervention of the first-aid

Art. EL 16, power supply circuits in security installations section 1a: "...the corresponding junction or deviation devices and their enclosures except for the waterproofing systems must satisfy the incandescent cable test defined in the standard in force, the temperature of the incandescent cable being 960 °C"

Viking 3 terminal blocks satisfy the incandescent cable test 960 °C according to standard IEC 60695-2-11

Viking 3 terminal blocks with spring connection

Characteristics and dimensions (mm)

V2 polyamide according to UL 94, 960°C according to IEC EN 60695-2-11

Connecting blocks

Cat. Nos.	Voltage (V)			Current (A)				Nominal cross-section		
	IEC	CSA	UL	le	IEC	CSA	UL	IEC (mm²)	CSA (AWG)	UL (AWG)
0372 00	800	600	600	36	32	20	20	4	12	12
0372 01				48	41	30	30	6	10	10
0372 02				63	57	50	50	10	8	8
0372 04				85	76	65	65	16	6	6
0372 07	500	300	300	36	32	20	20	4	12	12
0372 08										
0372 09	800	600	600	36	32	20	20	4	12	12
0372 20										
0372 21										
0372 40										
0372 41										
0372 42										
0372 43										
0372 44										
0372 46										
0372 47										
0372 60										
0372 61										
0372 62	500	300	300	36	32	30	30	4	10	10
0372 63										
0372 64										
0372 67										
0372 68	800	600	600	36	32	20	20	4	10	10
0372 69										

IEC 60947-7-1, CSA no. 22-2 no. 158, UL 1059
le: Rated current NF C 15100 table 52H, column 4

Blocks for protection conductor

Cat. Nos.	Voltage (V)			Nominal cross-section		
	IEC	CSA	UL	IEC (mm²)	CSA (AWG)	UL (AWG)
0372 10	800	600	600	4	10	10
0372 11						
0372 12						
0372 70						
0372 71						
0372 72						
0372 73 ⁽¹⁾						
0372 74 ⁽¹⁾						
0372 79	6	8	8			
	10	8	8			
	16	6	6			
	4	10	10			

IEC 60947-7-2, CSA no. 22-2 no. 158, UL 1059
(1) PEN terminal blocks

Function blocks

Cat. Nos.	Voltage (V)			Current (A)			Nominal cross-section		
	IEC	CSA	UL	IEC	CSA	UL	IEC (mm²)	CSA (AWG)	UL (AWG)
0372 54	500	300	300	1	1	1	4	14	14
0372 55									
0372 56									

IEC 60947-7-1, CSA no. 22-2 no. 158, UL 1059

Cat. Nos. 0372 00/01/
20/21/60/61/70/71

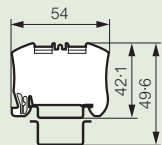

Cat. Nos. 0372 02/62/72

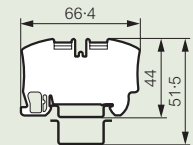

Cat. Nos. 0372 03/63/73

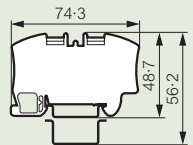

Cat. Nos. 0372 04/
64/74

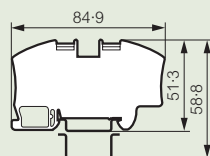

Cat. Nos. 0372 10/11/
40/41/42/43/44

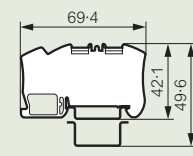

Cat. Nos. 0372 09/12/
46/47/54/69/79

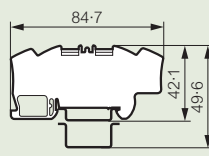

Cat. Nos. 0372 07/08/55/56/67/68

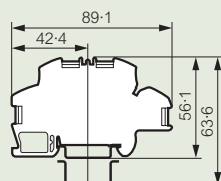

Schematic diagrams

Cat. No. 0372 54

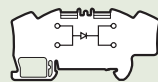

Cat. No. 0372 55

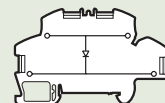

Cat. No. 0372 56

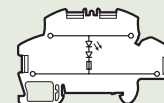

Diode for Cat. Nos. 0372 54/55

- 1N4007 type 1A
- direct current = 1 A
- peak inverse voltage 1 000 V
- inverse current 5 µA at 25°C

Approved by ATEX:

LCIE 07 ATEX 0010 U-0081 II 1 or 2 G or D Ex e/i/tD/iD II

The terminal blocks with spring connection covered by this certificate are 1- and 2-level connecting terminal blocks, and blocks for protection conductor with metal base (detailed list on p. 10)

The main characteristics are:

- Operating temperature: - 30°C to + 55°C
- Maximum temperature of materials: + 85°C

Working voltage acc. to EN 60079-7: 1-level terminal blocks: 500 V
Blocks with 2 entries - 2 outlets: 500 V
2-level terminal blocks: 250 V

Rated current:

Conductor cross-section (mm²)	4	6	10	16
Rated current (A)	23	30	42	57

Certificate of conformity of component for the customer is available on request

Disconnect blocks

Cat. Nos.	Voltage (V)			Current (A)			Nominal cross-section		
	IEC	CSA	UL	IEC	CSA	UL	IEC (mm²)	CSA (AWG)	UL (AWG)
0372 80	500	300	300	15	15	15	2.5	14	14
0372 81 or 0372 80 + 0375 15	250	250	250	6.3	6.3	6.3			
0372 82	500	300	300	15	15	15			
0372 83									
0372 84									
0372 85									
0372 86									

IEC 60947-7-1/7-3, CSA no. 22-2 no. 158, UL 1059

Power according to EN 60947-7-3

Cat. Nos.	Short-circuit		Short-circuit + overload	
	Separate blocks	Assembled blocks	Separate blocks	Assembled blocks
0372 81 or 0372 80 + 0375 15 ⁽¹⁾	4 W / 6.3 A Pvk = 4.75 W	1.6 W / 6.3 A Pvk = 2 W	1.6 W / 6.3 A Pv = 1.65 W	-

(1): With or without blown fuse indicator Cat. No. 0375 25

Cat. No. 0372 80

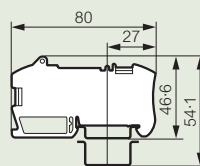

Cat. Nos. 0372 81/82/83/85

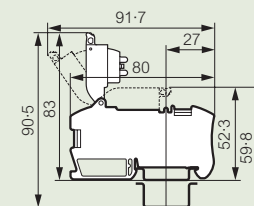

Cat. No. 0372 84/86

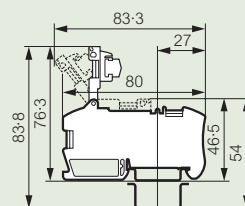

Viking 3 accessories for terminal blocks

Stripped lengths (mm)

Spring terminal width (mm)	Rigid or flexible cable
5	
6	8 to 12
8	
10	8 to 13
12	8 to 15

Protection against fire and panic risks in public buildings/UTE C 12-201 guide

Art. EL 3, definitions: "Security installations are those that have to be put into or maintained in service to ensure the evacuation of the public" or facilitate the intervention of the first-aid

Art. EL 16, power supply circuits in security installations section 1a: "...the corresponding junction or deviation devices and their enclosures except for the waterproofing systems must satisfy the incandescent cable test defined in the standard in force, the temperature of the incandescent cable being 960 °C"
Viking 3 terminal blocks satisfy the incandescent cable test 960 °C according to standard IEC 60695-2-11

■ Characteristics and dimensions (mm)

End stops

Cat. No. 0375 10

Cat. No. 0375 11

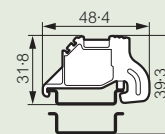
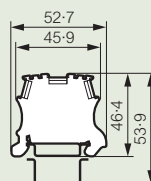

Cat. No. 0375 12

Cat. No. 0375 13

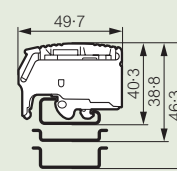
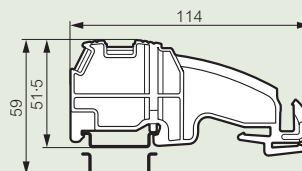

End caps

Cat. Nos.	Thickness (mm)
0375 50	2
0375 51	2.5
0375 52	2
0375 53	2
0375 54	2.5
0375 55	2
0375 56	1.4
0375 57	1.4
0375 86	1
0375 87	1.1
0375 88	1.1
0375 89	1.1
0375 90	2

Separation and insulation dividers

Cat. Nos.	Thickness (mm)
0375 54	2.5
0375 60	2.5
0375 61	2.6
0375 62	2.5
0375 63	2.5
0375 95	2.8
0375 96	2.7

Equipotential bridging combs/bars

Cat. Nos.	Cross-section (mm ²)
0375 01	2.5
0375 02	2.5
0375 04	4
0375 05	4
0375 07	6
0375 08	6
0375 40	10
0375 42	16
0375 44	35
0375 46	2.5
0375 47	2.5
0375 82	10
0375 85	16

Shielding clamps

Mounting on bar 10 x 3
Cat. No. 0375 34

Mounting on rail with accessory
Cat. No. 0364 69⁽¹⁾

Mounting on plate

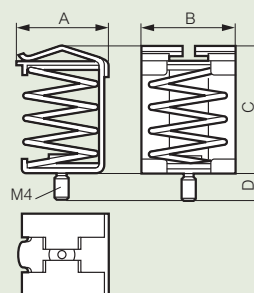
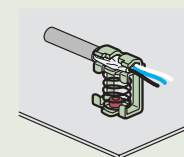
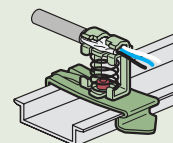
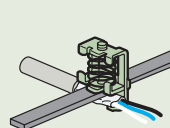

Cat. Nos.	A	B	C	D
0375 30	13.5	18	26	5.6
0375 31	20	20.3	31.4	5.3
0375 32	24.8	26	40	5.3

⁽¹⁾ For more information please refer to the current Legrand catalogue

Viking 3 heavy duty terminal blocks

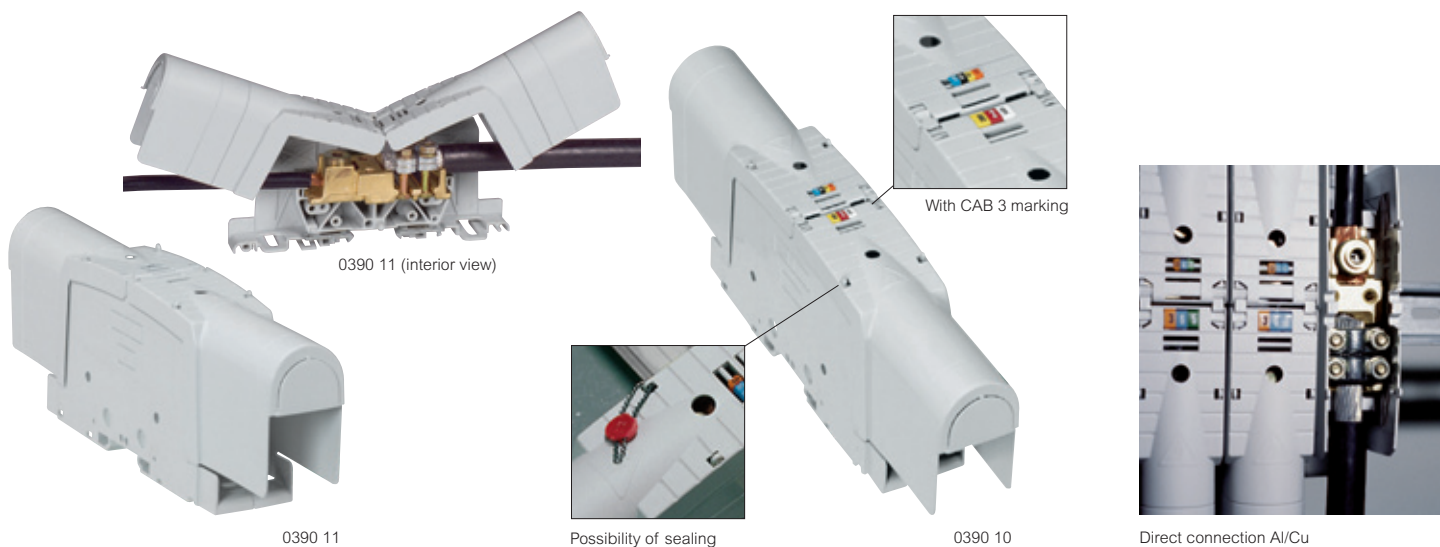

Pack	Cat. Nos.	For copper and aluminium cables		
		Bridging the gap between the enclosure and external cables Fixed using metal clip for rails \sqsubset 15 mm depth and \sqsubset EN 60715, 15 mm depth or on plate with screws Fitted with covers with cut-outs Permits the use of CAB 3 markers Test via test plug Ø4 closed covers Blocks with identical width can be joined using a threaded rod Supports shunt with Cat. Nos. 0394 46/47		
5	0390 10	Cable/cable	Rigid or flexible connecting cable (mm ²)	Width (mm)
5	0390 11	Al/Cu 35 to 120	Cu 35 to 70	42
		Al/Cu 70 to 300	Cu 70 to 150	55
		Terminal for cable lug/terminal for cable lug	Connecting plate max. (mm ²)	Width (mm)
5	0390 13	Al/Cu 95	Al/Cu 95	36
5	0390 14	Al/Cu 150	Al/Cu 150	42
5	0390 15	Al/Cu 300	Al/Cu 300	55
		Terminal for cable lug/cable	Connecting plate max. (mm ²)	Width (mm)
5	0390 17	Al/Cu 150	Cu 35 to 95	42
5	0390 18	Al/Cu 300	Cu 70 to 150	55
		Cable/terminal for cable lug	Connecting plate max. (mm ²)	Width (mm)
5	0390 20	Cu 35 to 120	Al/Cu 120	42
5	0390 21	Al 35 to 120	Al/Cu 70	
		Cu 70 to 300	Al/Cu 300	55
		Al 70 to 300	Al/Cu 150	

Pack	Cat. Nos.	Accessories for heavy duty terminal blocks for copper and aluminium cables	
5	0394 46	Shunt	
5	0394 47	For blocks with width 55 mm	

Pack	Cat. Nos.	Plate power terminal blocks			
		Bridging the gap between the enclosure and external cables Plastic foot For use with terminal marker sheets For symmetrical rails Fixed using metal clip on rails \sqsubset 15 mm depth and \sqsubset EN 60715, 15 mm depth			
		Connecting max. (mm ²)	Width of plate (mm)	Screw Ø	Width (mm)
5	0390 71	35	15	M 8	26
5	0390 72	70	20	M 10	34
5	0390 73	120	25	M 10	34
5	0390 74	240	35	M 12	46
		For asymmetrical rails			
		Fixed using metal clip on rails \sqsubset EN 60715			
5	0390 31	35	15	M 8	26
5	0390 32	70	20	M 10	34
5	0390 33	120	25	M 10	34
5	0390 34	240	35	M 12	46

Pack	Cat. Nos.	Accessories for heavy duty plate terminal blocks	
		Separation barriers	
		Take protective covers	
		Marking possible with CAB 3	
10	0394 77	For terminals with width 26 mm	
10	0394 78	For terminals with width 34 and 46 mm	
		Protective covers	
		For mounting on separation barriers	
5	0394 86	For 3 terminals with width 46 mm or for 4 terminals with width 34 mm	
5	0394 88	For 4 terminals with width 26 mm	
5	0394 89	For 4 terminals with width 46 mm	



End stops (p. 19)

Viking 3 heavy duty terminal blocks

Characteristics of heavy duty terminal blocks for copper and aluminium cables

IK 04
 Conform to IEC 60947-7-1, EN 60947-7-1
 UL 1059 and 486 E - CSA 22-2
 Fire resistant IEC 60695-2-11: 960°C (except cover)
 V2 according to UL 94
 Insulation voltage U_i : 1000 V
 Impulse voltage U_{imp} : 12 kV
 Insulating material:
 - polyamide body - 30 °C to + 100 °C
 - polypropylene cover - 25 °C to + 100 °C

Connection table

Cat. Nos.	Connection (mm ²)	Width of plate (mm)	Screw \varnothing	Connection (mm ²)	Width of plate (mm)	Screw \varnothing	Width (mm)
Cable - Cable							
0390 10	Rigid or flexible Cu/Al: 35 to 120			Rigid or flexible Cu: 35 to 70			42
0390 11	Rigid or flexible Cu/Al: 70 to 300			Rigid or flexible Cu: 70 to 150			55
Terminal for cable lug - Terminal for cable lug							
0390 13	Cu/Al: max. 95	28	M 8	Cu/Al: max. 95	28	M 8	36
0390 14	Cu/Al: max. 150	34	M 10	Cu/Al: max. 150	34	M 10	42
0390 15	Cu/Al: max. 300	46	M 12	Cu/Al: max. 300	46	M 12	55
Terminal for cable lug - Cable							
0390 17	Cu/Al: max. 150	34	M 10	Rigid or flexible Cu: 35 to 95			42
0390 18	Cu/Al: max. 300	46	M 12	Rigid or flexible Cu: 70 to 150			55
Cable - Terminal for cable lug							
0390 20	Rigid or flexible Cu: 35 to 120 Al: 35 to 120			Cu/Al: max. 120 Cu/Al: max. 70	34 34	M 10 M 10	42 42
0390 21	Rigid or flexible Cu: 70 to 300 Al: 70 to 300			Cu/Al: max. 300 Cu/Al: max. 150	46 46	M 12 M 12	55 55

Cable - cable

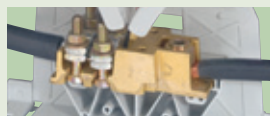

Terminal for cable lug - cable



Terminal for cable lug - terminal for cable lug



Cable - terminal for cable lug

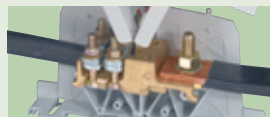

Currents table

Cat. Nos.	Current (A)				Short-circuit current (kA)		Tightening torque (Nm)		Width (mm)
	Shunted input		I/O currents		Shunted input	I/O	Site	Factory	
	IEC	IEC	CSA	UL					
Cable - Cable									
0390 10	340	250	200	170	14.4	8.4	15	15	42
0390 11	570	400	300	285	36	18	35	35	55
Terminal for cable lug - Terminal for cable lug									
0390 13	310	310	250	230	11.4	11.4	15	15	36
0390 14	415	415	340	285	18	18	15	15	42
0390 15	670	670	520	420	36	36	35	35	55
Terminal for cable lug - Cable									
0390 17	415	315	210	230	18	11.4	15	15	42
0390 18	670	420	325	285	36	18	35	35	55
Cable - Terminal for cable lug									
0390 20	340	340	235	255	14.4	8.4	15	15	42
0390 21	570	570	375	420	36	18	35	35	55
Shunts									
0394 46	450 max.							6	
0394 47	700 max.							10	

Cable section equivalence table

mm ²	35	70	95	120	150	185	300
AWG	2	00	0000	250	300	350	600

Dimensions (mm)

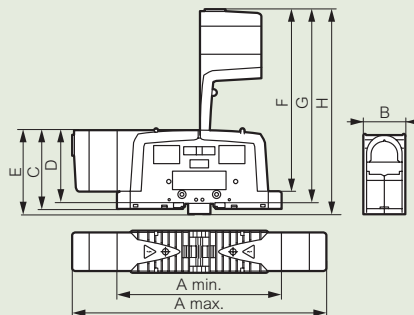

Cat. Nos.	A max.	A min.	B	C	D	E	F	G	H
0390 13	227	155	36	82	73	88	176	185	191
0390 10/14/17/20	296	200	42	83.5	74.5	89.5	212	221	227
0390 11/15/18/21	337	216	55	107.3	98.5	113.5	257	266	272

Characteristics of heavy duty plate terminal blocks

Cat. Nos.	Voltage (V) IEC	Intensity (A) IEC	IEC EN 60947-7-1 Fire resistance: 960°C, IEC EN 60695-2-11 V2 according to UL 94 Insulating material: polyamide - 30 °C to + 100 °C
0390 31/71	1000	125	
0390 32/72	1000	192	
0390 33/73	1000	269	
0390 34/74	1000	415	

Dimensions (mm)

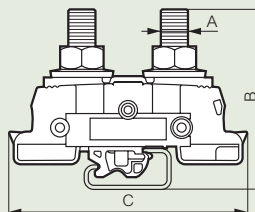

Cat. Nos. 0390 31/32/33/34

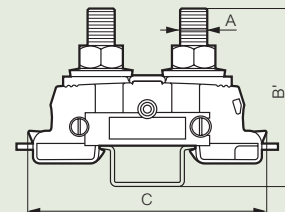

Cat. Nos. 0390 71/72/73/74

Cat. Nos.	A	B	B'	C
0390 31	M 8	56		84
0390 32	M 10	61		84
0390 33	M 10	61		84
0390 34	M 12	64		86
0390 71	M 8		55.3	84
0390 72	M 10		60.4	84
0390 73	M 10		60.4	84
0390 74	M 12		63.5	86

Separation barriers

Dimensions (mm)

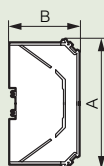

Cat. Nos. 0394 77/78

Cat. Nos.	A	B	Thickness
0394 77	106	82	8
0394 78	188	102	12

Perfect connections...

Create reliable connections in seconds with Starfix crimping tools and ferrules... everything you need for cable widths from 0.25 to 50mm.



Crimping tool, applicator and ferrules are available in convenient kits to get you started



Fit the applicator



Adjust cable size



Insert cable and crimp

Starfix crimping tools are suitable for cables from 0.25 to 6 mm²



Adjust cross-section

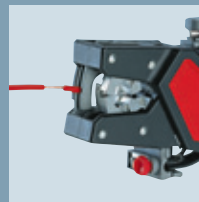

Strip and twist

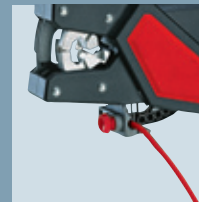

Crimp

Cut, strip and crimp cables with the Starfix S

... clearly marked



CAB 3 offers a high quality solution to multiple cable and terminal marking requirements. Universal fittings enable clear, rapid marking and simple modification.

- available in 3 marker widths: 5, 6 and 8 mm
- numbers from 1 to 500
- terminal markings can be done before or after connection
- international marker colours

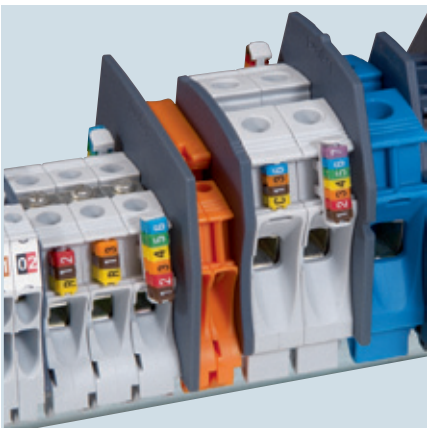

Fast, secure connections, easily and clearly marked complete the highest quality installations

marking system for Viking 3 terminal blocks

CAB 3[®] marking system for cables and Viking 3 terminal blocks

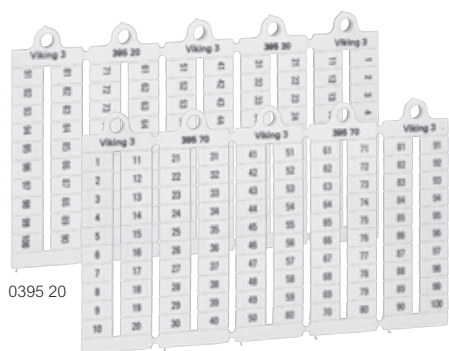

0395 20

0395 70

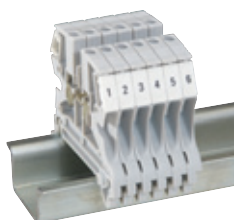

0395 98

0395 05 on Viking 3
terminal blocks

0381 64

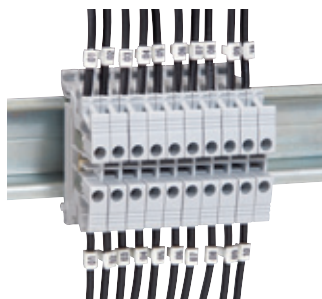

Same markers for cable and terminal blocks

Strips of 20 markers
For cables or Viking 3 terminal blocks

Pack	Cat. Nos.	Blank markers
1000	0395 00	Displayed by sheet of 100 pre-cut markers Manual marking or via Logiccab 2 For blocks 5 mm width
1000	0395 01	For blocks 6 mm width
1000	0395 02	For blocks 8 mm width

Numbers		
Horizontal format		
Width of 5 mm		
1000	0395 05	From 1 to 10 (10 times)
1000	0395 06	From 11 to 20 (10 times)
1000	0395 09	From 1 to 50 (2 times)
1000	0395 10	From 1 to 100
Width of 6 mm		
1000	0395 15	From 1 to 10 (10 times)
1000	0395 16	From 11 to 20 (10 times)
1000	0395 19	From 1 to 50 (2 times)
1000	0395 20	From 1 to 100
1000	0395 21	From 101 to 200

Black felt tip pen		
10	0395 98	Permanent marker

Pack	Cat. Nos.	Markers for cables 1.5 to 2.5 mm ² cross-section and terminal blocks
Numbers: black on white background (available in black on yellow background on request)		
240	0381 60	01 to 20
240	0381 61	21 to 40
240	0381 62	41 to 60
240	0381 63	61 to 80
240	0381 64	81 to 100
240	0381 65	Blank



0381 64

CAB 3[®] marking system for cables and Viking 3 terminal blocks



Perfect alignment of label holders



0382 12

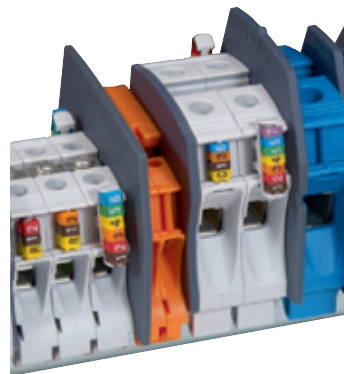

Terminal block with CAB 3 markers and label holders

Pack ⁽¹⁾	Cat. Nos.		Markers for cables 0.15 to 0.5 mm ² and 0.5 to 1.5 mm ² cross-section and terminal blocks
	0.15 to 0.5 ²	0.5 to 1.5 ²	
1 000	1 200	0381 00	0382 10
1 000	1 200	0381 01	0382 11
1 000	1 200	0381 02	0382 12
1 000	1 200	0381 03	0382 13
1 000	1 200	0381 04	0382 14
1 000	1 200	0381 05	0382 15
1 000	1 200	0381 06	0382 16
1 000	1 200	0381 07	0382 17
1 000	1 200	0381 08	0382 18
1 000	1 200	0381 09	0382 19
300	0381 10	0383 00	A
300	0381 11	0383 01	B
300	0381 12	0383 02	C
300	0381 13	0383 03	D
300	0381 14	0383 04	E
300	0381 15	0383 05	F
300	0381 16	0383 06	G
300	0381 17	0383 07	H
300	0381 18	0383 08	I
300	0381 19	0383 09	J
300	0381 20	0383 10	K
300	0381 21	0383 11	L
300	0381 22	0383 12	M
300	0381 23	0383 13	N
300	0381 24	0383 14	O
300	0381 25	0383 15	P
300	0381 26	0383 16	Q
300	0381 27	0383 17	R
300	0381 28	0383 18	S
300	0381 29	0383 19	T
300	0381 30	0383 20	U
300	0381 31	0383 21	V
300	0381 32	0383 22	W
300	0381 33	0383 23	X
300	0381 34	0383 24	Y
300	0381 35	0383 25	Z
300	0381 40	0382 70	/
300	0381 41	0382 71	•
300	0381 42	0382 72	+
300	0381 43	0382 73	-
300	0381 44	0382 74	~
300	0381 45	0382 75	≡
300	0381 46	0382 76	⊕

Markers for cables 0.15 to 0.5 mm² and 0.5 to 1.5 mm² cross-section and terminal blocks

On Viking 3 terminal blocks
- 4 markers 0.15 to 0.5 mm² max.
- 3 markers 0.15 to 1.5 mm² max.

Digits: international colour code

0	Black
1	Brown
2	Red
3	Orange
4	Yellow
5	Green
6	Blue
7	Purple
8	Grey
9	White

Letters: black on yellow background

Conventional symbols: black on yellow background

Pack ⁽¹⁾	Cat. Nos.		Markers for cables 1.5 to 2.5 mm ² and 4 to 6 mm ² cross-section
	1.5 to 2.5 ²	4 to 6 ²	
1 200	800	0382 20	0382 30
1 200	800	0382 21	0382 31
1 200	800	0382 22	0382 32
1 200	800	0382 23	0382 33
1 200	800	0382 24	0382 34
1 200	800	0382 25	0382 35
1 200	800	0382 26	0382 36
1 200	800	0382 27	0382 37
1 200	800	0382 28	0382 38
1 200	800	0382 29	0382 39
300	0383 30	0383 60	A
300	0383 31	0383 61	B
300	0383 32	0383 62	C
300	0383 33	0383 63	D
300	0383 34	0383 64	E
300	0383 35	0383 65	F
300	0383 36	0383 66	G
300	0383 37	0383 67	H
300	0383 38	0383 68	I
300	0383 39	0383 69	J
300	0383 40	0383 70	K
300	0383 41	0383 71	L
300	0383 42	0383 72	M
300	0383 43	0383 73	N
300	0383 44	0383 74	O
300	0383 45	0383 75	P
300	0383 46	0383 76	Q
300	0383 47	0383 77	R
300	0383 48	0383 78	S
300	0383 49	0383 79	T
300	0383 50	0383 80	U
300	0383 51	0383 81	V
300	0383 52	0383 82	W
300	0383 53	0383 83	X
300	0383 54	0383 84	Y
300	0383 55	0383 85	Z
300	0382 80	0382 90	/
300	0382 81	0382 91	•
300	0382 82	0382 92	+
300	0382 83	0382 93	-
300	0382 84	0382 94	~
300	0382 85	0382 95	≡
300	0382 86	0382 96	⊕

Digits: international colour code

0	Black
1	Brown
2	Red
3	Orange
4	Yellow
5	Green
6	Blue
7	Purple
8	Grey
9	White

Letters: black on yellow background

Conventional symbols: black on yellow background

(1) Up to 0.5 mm²: strips of 25 markers
From 0.5 mm² to 2.5 mm²: strips of 30 markers
Upper 2.5 mm²: strips of 20 markers
Price per marker

CAB 3[®] marking system accessories



Pack Cat. Nos. CAB 3 accessories

Pack	Cat. Nos.	CAB 3 accessories
		Marker holders For cables cross-section from 10 mm ² to 70 mm ² Capacity: 8 digits, letters or symbols markers from 0.5 to 1.5 mm ² or 1.5 to 2.5 mm ² cross section Black, cross-section (mm ²)
100	0384 90	10 to 16
50	0384 91	25 to 35
50	0384 92	50 to 70
		Support for markers Can be clipped on to Viking 3 terminal blocks Capacity: 7 markers from 0.15 to 0.5 mm ² 6 markers from 0.5 to 1.5 mm ²
100	0383 92	
		Transparent applicators For rapid selection and application of markers on to cable
		For markers cross-section (mm ²) Applicator colour for identification of cross-section
10	0383 94	0.15 to 0.5 CAB 3
10	0383 95	0.5 to 1.5 CAB 3
10	0383 96	1.5 to 2.5 CAB 3
10	0383 97	4 to 6 CAB 3
		Set of markers
1	0382 01	0.15 to 0.5 mm ² : 2 500 markers + 10 applicators (250 digits from 0 to 9)
1	0382 02	0.5 to 1.5 mm ² : 3 000 markers + 10 applicators (300 digits from 0 to 9)
1	0382 03	1.5 to 2.5 mm ² : 3 000 markers + 10 applicators (300 digits from 0 to 9)
1	0382 04	4 to 6 mm ² : 2 000 markers + 10 applicators (200 digits from 0 to 9)
		On-site toolbox
1	0382 00	With removable tray for CAB 3 markers and applicators, Starfix ferrules etc. Height 85 mm, depth 280 mm, width 450 mm Metal, padlockable

CAB 3[®] marking system for cables and Viking 3 terminal blocks

■ Dimensions

Markers

Polyamide 6/6

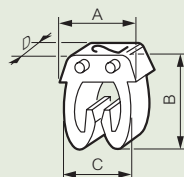

Dimensions	Cable cross-section (mm ²)			
	0.15 to 0.5	0.5 to 1.5	1.5 to 2.5	4 to 6
A (mm)	5	5	5.6	8
B (mm)	5.05	6.4	7.6	9.6
C (mm)	3.7	4.3	4.9	7.1
D (mm)	2.3	3	3	3
Ø min./max. (mm)	0.8/2.2	2.2/3	2.8/3.8	4.3/5.3

Marker holders

Cat. No. 0384 90

Cat. No. 0384 91

Cat. No. 0384 92

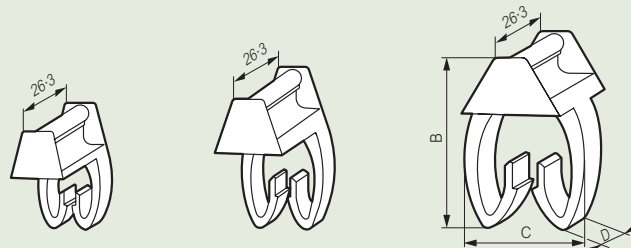

Dim.	Section of cable for marking (mm ²)		
	10 to 16	25 to 35	50 to 70
A (mm)	18	24.3	27.2
B (mm)	8.9	12.2	17.2
C (mm)	7	7	10

Support for markers Cat. No. 0383 92

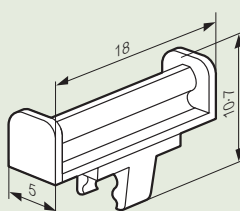

On cable with marker holder
Cat. No. 0384 92



■ Characteristics and dimensions of on-site toolbox

Cat. No. 0382 00

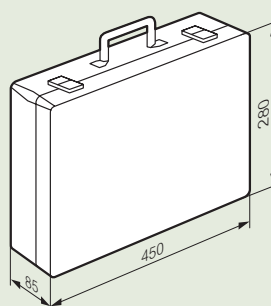

Bottom tray consists of:

- 8 medium slots (each slot takes 1 box of CAB 3)
- 1 large slot

Top tray consists of:

- 12 small slots (<=> approx. 6 boxes of CAB 3)
- 1 medium slot for applicators

Capacity: approx. 15 000 CAB 3 markers

On terminal blocks, with label holder
Cat. No. 0383 92



On heavy duty terminal blocks

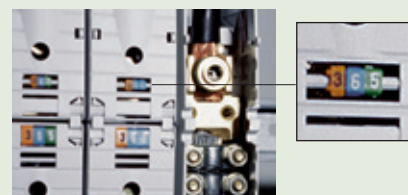

Starfix® ferrules and crimping tools

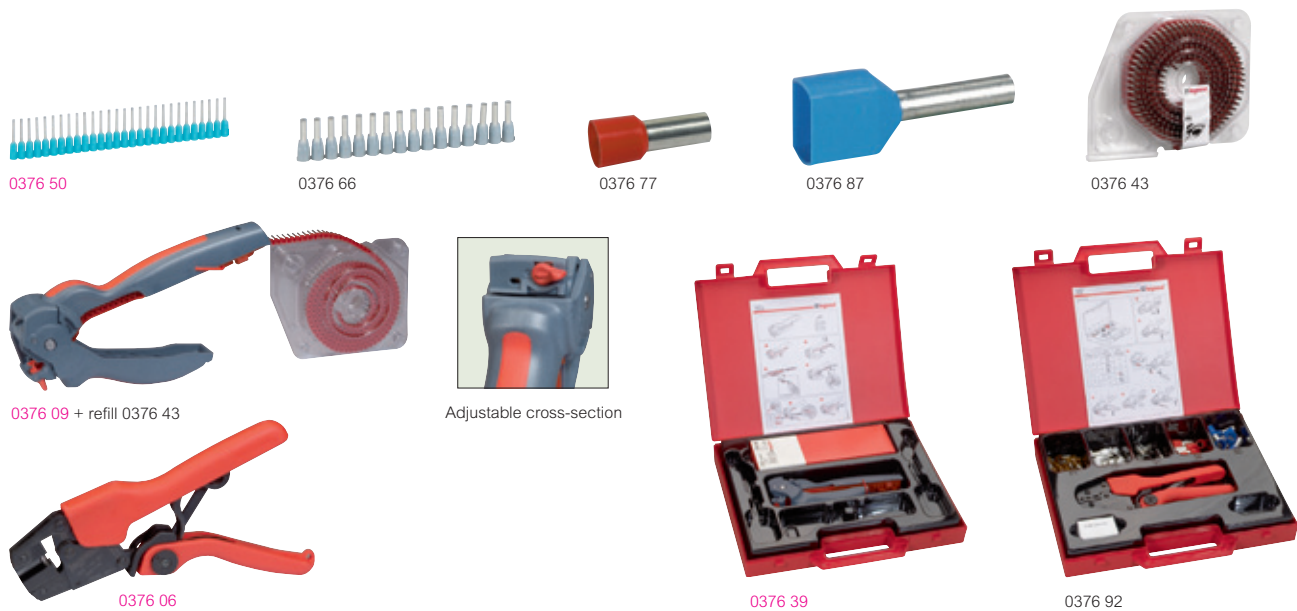

Pack	Cat. Nos.	Ferrules with insulating flange			
		Provide an equipotential link for all the strands of a flexible conductor Active part in tinned electrolytic copper Conform to NF C 63-023			
		Single ferrules (in strips)			
		For cables cross-section (mm ²)	Colour	Strips	Ferrules
500	0376 50	0-25	turquoise	10	50
500	0376 60	0-34	green	12	40
480	0376 61	0-5	white	12	40
480	0376 62	0-75	blue	12	40
1000	0376 63	1	red	25	40
1000	0376 64	1-5	black	25	40
1000	0376 66	2-5	grey	25	40
250	0376 67	4	orange	10	25
250	0376 68	6	green	10	25
		Single ferrules (in sachets)			
500	0377 50	0-25	turquoise	5	100
500	0377 60	0-34	green	10	100
480	0377 61	0-5	white	10	100
480	0377 62	0-75	blue	10	100
1000	0377 63	1	red	10	100
1000	0377 64	1-5	black	10	100
1000	0377 66	2-5	grey	10	100
250	0377 67	4	orange	10	100
250	0377 68	6	green	5	50
		Single ferrules (individual)			
100	0376 69	10	brown		
100	0376 70	16	white		
50	0376 71	25	black		
		Double ferrules			
100	0376 87	2 x 0-75	blue		
100	0376 88	2 x 1	red		
100	0376 89	2 x 1-5	black		
100	0376 90	2 x 2-5	grey		

Pack	Cat. Nos.	Large capacity Starfix refills		
		Large capacity for less frequent applicator reloading Translucent packaging For direct mounting on crimping tool Cat. No. 0376 09		
		Cross-section (mm ²)	Colour	Number of ferrules per strip
3000	0376 41	0-5	White	300
3000	0376 42	0-75	Blue	300
3000	0376 43	1	Red	300
3000	0376 44	1-5	Black	300
2500	0376 45	2-5	Grey	250

Pack	Cat. Nos.	Crimping tools for ferrules in strips	
		Cut and carry out 4-point crimping of ferrules from 0-25 to 6 mm ² in one operation Recommended for spring connections Dedicated applicator for each crimping tool for dispensing strips	
1	0376 08	Starfix crimping tool for 0-25 and 0-34 mm² cross-sections Supplied with empty applicator fitted	
1	0376 09	Starfix crimping tool for 0-5 to 2-5 mm² cross-sections Fitted with an adjustment wheel Supplied with empty applicator fitted	
1	0376 39	Assorted kit, comprising: - 1 Starfix crimping tool, Cat. No. 0376 09 with empty applicator fitted - 120 x 0-5 mm ² ferrules - 120 x 0-75 mm ² ferrules - 240 x 1 mm ² ferrules - 320 x 1-5 mm ² ferrules - 200 x 2-5 mm ² ferrules	
1	0376 10	Starfix crimping tool for 4 and 6 mm² cross-sections Fitted with an adjustment wheel Supplied complete with empty applicator	
1	0376 97	Starfix S multi-purpose crimping tool for 0-5 to 2-5 mm² cross-sections Tool cuts, strips, twists, crimps Supplied complete with 5 empty applicators For left and right-handed usage	
1	0376 06	Crimping tool for single and double ferrules Starfix crimping tool for 0-25 to 6 mm² cross-sections For 4-point crimping of ferrules from 0-25 to 6 mm ² Recommended for spring connections Crimping tool with disengageable control system, crimping at end Right or left-handed	
1	0376 92	Starfix clamp for 10 to 50 mm² cross-section Assorted kit. Supplied with: - 1 tool with crimping operation control system for individual ferrules 10 to 50 mm ² - 30 individual ferrules 10 mm ² - 20 individual ferrules 16 mm ² - 15 individual ferrules 25 mm ² - 10 individual ferrules 35 mm ² - 10 individual ferrules 50 mm ²	

Starfix® applicators



0376 47



0376 81

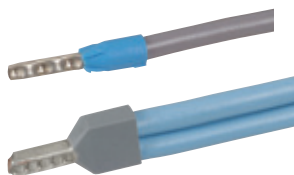

Example of single/double ferrules on cables



Example of different cables and ferrules

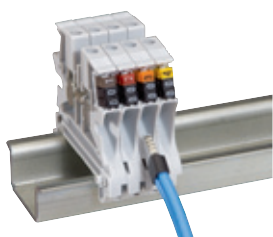

Pack	Cat. No.	Starfix applicators
	NEW	For Starfix crimping tool
		For dispensing strips of ferrules in Starfix crimping tools Cat. Nos. 0376 08/09/10/97
		For ferrules cross-section (mm ²)
10	0376 46	0.25 and 0.34
10	0376 47	0.5 to 2.5
10	0376 48	4 and 6
		Colour
		yellow
		red
		orange
		For Starfix S multi-purpose crimping tool
		For dispensing colour-coded strips of ferrules
		Removable transparent cover
		For ferrules cross-section (mm ²)
5	0376 80	0.5
5	0376 81	0.75 ⁽¹⁾
5	0376 82	1 ⁽¹⁾
5	0376 83	1.5
5	0376 84	2.5
		Colour
		white
		blue
		red
		black
		grey

For Starfix crimping tool

For dispensing strips of ferrules in Starfix crimping tools Cat. Nos. 0376 08/09/10/97

For ferrules cross-section (mm²)

0.25 and 0.34

0.5 to 2.5

4 and 6

Colour

yellow

red

orange

For Starfix S multi-purpose crimping tool

For dispensing colour-coded strips of ferrules

Removable transparent cover

For ferrules cross-section (mm²)

0.5

0.75⁽¹⁾

1⁽¹⁾

1.5

2.5

Colour

white

blue

red

black

grey

Starfix® applicators

Correspondance table

Cross-section (mm ²)				
Ferrule	Single ferrule	Large capacity ferrule - refills	Starfix applicator	Starfix S applicator
0-5	0376 61	0376 41	0376 47	0376 80
0-75	0376 62	0376 42	0376 47	0376 81
1	0376 63	0376 43	0376 47	0376 82
1-5	0376 64	0376 44	0376 47	0376 83
2-5	0376 66	0376 45	0376 47	0376 84

Dimensions (mm)

Single ferrules

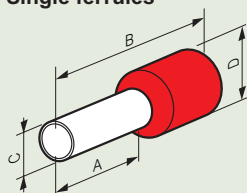

Cat. Nos.	Cross-section (mm ²)	A	B	C	D
0376 50	0.25	8	14.5	1.1	3
0376 60	0.34	8	14.5	1.1	3
0376 61 0376 41	0.5	8	14.5	1.5	3.4
0376 62 0376 42	0.75	8	14.5	1.5	3.4
0376 63 0376 43	1	8	14.5	1.7	3.6
0376 64 0376 44	1.5	8	14.5	2	4.1
0376 66 0376 45	2.5	8	14.5	2.6	4.8
0376 67	4	12	21	3.2	5.7
0376 68	6	12	23	3.9	7.2
0376 69	10	12	21	4.9	8.1
0376 70	16	18	29	6.3	9.8
0376 71	25	18	31	7.9	12

Double ferrules

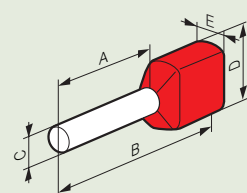

Cat. Nos.	Cross-section (mm ²)	A	B	C	D	E
0376 87	2 x 0.75	8	15	2.1	6	3.3
0376 88	2 x 1	8	15	2.35	6	4
0376 89	2 x 1.5	8	16	2.6	7.2	4.2
0376 90	2 x 2.5	10	18.5	3.3	8.4	4.8

Starfix usage example



1 Fit the applicator



2 Adjust



The 2 material handle gives an excellent grip

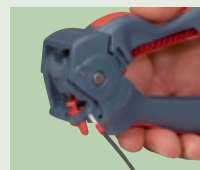

3 Insert the cable



4 Crimp

Starfix S usage example

Starfix S tool



1 Adjust the cross-section

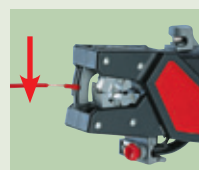

2 Strip and twist

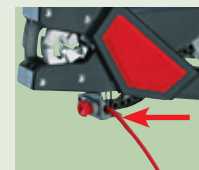

3 Crimp

(1) If Tri-rated use one size larger applicator

Numeric index

Cat. Nos.	Page No.	Pack	Cat. Nos.	Page No.	Pack	Cat. Nos.	Page No.	Pack	Cat. Nos.	Page No.	Pack	Cat. Nos.	Page No.	Pack
0371 00			0372 09			0375 25			0376 62					
0371 00	14	60	0372 09	16	50	0375 25	19	10	0376 62	30	480	27	-	300
01	-	50	10	-	40	27	-	10	63	-	1000	28	-	300
02	-	40	11	-	30	30	-	10	64	-	1000	0381 29	28	300
03	-	30	12	-	40	31	-	10	66	-	1000	30	-	300
04	-	20	20	-	60	32	-	4	67	-	250	31	-	300
05	-	20	21	-	50	34	-	10	68	-	250	32	-	300
07	-	60	40	-	60	35	-	50	69	-	100	33	-	300
08	-	60	41	-	60	40	-	10	70	-	100	34	-	300
09	-	25	42	-	60	42	-	10	71	-	50	35	-	300
20	-	60	43	-	50	44	-	10	80	31	5	40	-	300
21	-	50	44	-	50	46	-	10	81	-	5	41	-	300
30	-	60	46	-	60	47	-	10	82	-	5	42	-	300
31	-	50	47	-	60	50	18	100	83	-	5	43	-	300
51	-	50	54	17	60	51	-	20	84	-	5	44	-	300
52	-	50	55	-	60	52	-	20	87	30	100	45	-	300
53	15	20	56	-	60	53	-	20	88	-	100	46	-	300
54	-	20	60	16	60	54	-	20	89	-	100	60	-	240
55	-	60	61	-	50	55	-	20	90	-	100	61	-	240
56	-	60	62	-	50	56	-	20	92	-	1	62	-	240
60	14	60	63	-	40	57	-	10	97	-	1	63	-	240
61	-	50	64	-	10	60	-	20	0377 00			64	-	240
62	-	40	67	-	60	61	-	10	0377 50	30	500	65	-	240
63	-	30	68	-	50	62	-	10	60	-	500	0382 00		
64	-	20	69	-	50	63	-	10	61	-	480	0382 00	29	1
65	-	20	70	-	60	65	19	10	62	-	480	01	-	1
66	-	10	71	-	50	66	-	10	63	-	1000	02	-	1
67	-	60	72	-	25	67	-	10	64	-	1000	03	-	1
68	-	60	73	-	20	68	-	10	66	-	1000	04	-	1
69	-	25	74	-	15	69	-	10	67	-	250	10	28	1200
70	-	60	79	-	30	75	-	50	68	-	250	11	-	1200
71	-	50	80	17	20	76	-	20	0381 00			12	-	1200
72	-	40	81	-	20	77	-	10	0381 00	28	1000	13	-	1200
73	-	30	82	-	20	82	-	20	01	-	1000	14	-	1200
74	-	10	83	-	20	85	-	20	02	-	1000	15	-	1200
75	-	10	84	-	20	86	18	50	03	-	1000	16	-	1200
76	-	10	85	-	20	87	-	50	04	-	1000	17	-	1200
77	-	50	86	-	20	88	-	20	05	-	1000	18	-	1200
78	-	40	0374 00			89	-	20	06	-	1000	19	-	1200
79	-	50	0374 04	18	10	90	-	20	07	-	1000	20	-	1200
80	15	20	07	-	10	95	-	10	08	-	1000	21	-	1200
81	-	20	0375 00			96	-	10	09	-	1000	22	-	1200
82	-	20	0375 01	18	20	0376 00			10	-	300	23	-	1200
83	-	20	02	-	50	0376 06	30	1	11	-	300	24	-	1200
84	-	20	04	-	20	08	-	1	12	-	300	25	-	1200
85	-	20	05	-	50	09	-	1	13	-	300	26	-	1200
86	-	20	07	-	20	10	-	1	14	-	300	27	-	1200
87	-	20	08	-	20	39	-	1	15	-	300	28	-	1200
88	-	20	10	-	50	41	-	3000	16	-	300	29	-	1200
92	-	25	11	-	20	42	-	3000	17	-	300	30	-	800
0372 00			12	-	10	43	-	3000	18	-	300	31	-	800
0372 00	16	60	13	-	20	44	-	3000	19	-	300	32	-	800
01	-	50	15	19	10/50	45	-	2500	20	-	300	33	-	800
02	-	50	16	-	10/50	46	31	10	21	-	300	34	-	800
03	-	40	17	-	10/50	47	-	10	22	-	300	35	-	800
04	-	10	18	-	10/50	48	-	10	23	-	300	0382 36	28	800
07	-	60	21	-	20	50	30	500	24	-	300	37	-	800
08	-	50	22	-	20	60	-	500	25	-	300	38	-	800
			24	-	10/50	61	-	480	26	-	300	39	-	800

Bold pack quantities: Minimum quantities to be ordered
Red catalogue numbers: New products

Cat. Nos.	Page No.	Pack	Cat. Nos.	Page No.	Pack	Cat. Nos.	Page No.	Pack	Cat. Nos.	Page No.	Pack	Cat. Nos.	Page No.	Pack
70	-	300	09	-	300	44	-	300	79	-	300	72	-	5
71	-	300	10	-	300	45	-	300	80	-	300	0390 73	24	5
72	-	300	11	-	300	46	-	300	81	-	300	74	-	5
73	-	300	12	-	300	47	-	300	82	-	300	0394 00		
74	-	300	13	-	300	48	-	300	83	-	300	0394 46	24	5
75	-	300	0383 14	28	300	49	-	300	84	-	300	47	-	5
76	-	300	15	-	300	50	-	300	85	-	300	49	18	10
80	-	300	16	-	300	51	-	300	92	29	100	77	24	10
81	-	300	17	-	300	52	-	300	94	-	10	78	-	10
82	-	300	18	-	300	53	-	300	95	-	10	86	-	5
83	-	300	19	-	300	54	-	300	96	-	10	88	-	5
84	-	300	20	-	300	55	-	300	97	-	10	89	-	5
85	-	300	21	-	300	60	-	300	0384 00			0395 00		
86	-	300	22	-	300	61	-	300	0384 90	29	100	0395 00	27	1000
90	-	300	23	-	300	0383 62	28	300	91	-	50	01	-	1000
91	-	300	24	-	300	63	-	300	92	-	50	02	-	1000
92	-	300	25	-	300	64	-	300	0390 00			05	-	1000
93	-	300	30	-	300	65	-	300	0390 10	24	5	06	-	1000
94	-	300	31	-	300	66	-	300	11	-	5	09	-	1000
95	-	300	32	-	300	67	-	300	13	-	5	10	-	1000
96	-	300	33	-	300	68	-	300	14	-	5	15	-	1000
0383 00			34	-	300	69	-	300	15	-	5	16	-	1000
0383 00	28	300	35	-	300	70	-	300	17	-	5	19	-	1000
01	-	300	36	-	300	71	-	300	18	-	5	20	-	1000
02	-	300	37	-	300	72	-	300	20	-	5	21	-	1000
03	-	300	38	-	300	73	-	300	21	-	5	96	18	20
04	-	300	39	-	300	74	-	300	31	-	5	97	-	20
05	-	300	40	-	300	75	-	300	32	-	5	98	18	10
06	-	300	41	-	300	76	-	300	33	-	5			
07	-	300	42	-	300	77	-	300	34	-	5			
08	-	300	43	-	300	78	-	300	71	-	5			

In accordance with its policy of continuous improvement, the Company reserves the right to change specifications and designs without notice. All illustrations, descriptions, dimensions and weights in this catalogue are for guidance and cannot be held binding on the Company.

The Legrand logo is a registered trademark of the Legrand Group of companies.



Customer Services :

Tel : 0845 605 4333 Fax : 0845 605 4334

E-mail : legrand.sales@legrand.co.uk

Technical Support :

Tel : 0870 608 9020 Fax : 0870 608 9021

E-mail : technical.uk@legrand.co.uk

Head office :

Legrand Electric Limited
Great King Street North, Birmingham, B19 2LF
Tel : 0870 608 9000 Fax : 0870 608 9004

Website : www.legrand.co.uk